

Operating
and safety instructions.
Windows.

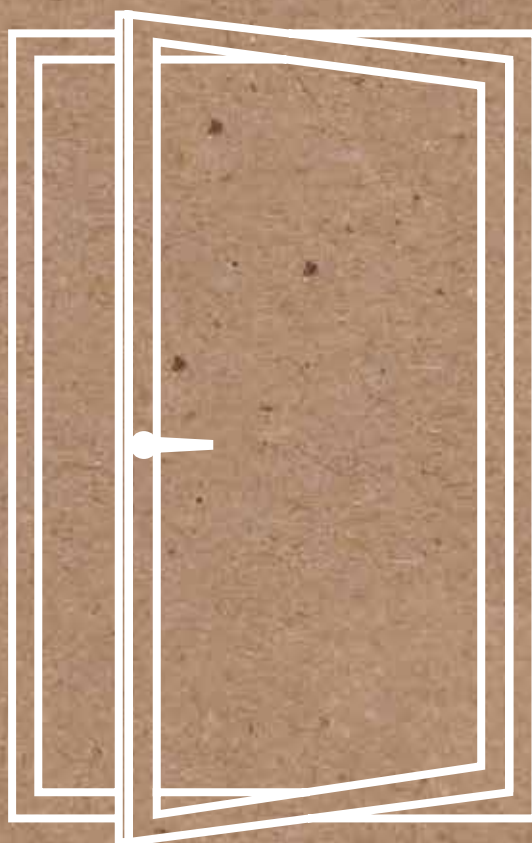



Dear Customer,

thank you for choosing Finstral products.

In these operating instructions, we cover the most common topics for the proper operation and cleaning of our products. Some special equipment is not part of this manual, but is described in separate documents. If you have not been given the instructions in paper form, you can request them from your contract partner. In addition, all the manuals are also available at any time at finstral.com/manuals. Should there ever be any uncertainties or problems, your contract partner will of course be there for you.

We are sure that you will enjoy your Finstral products for a long time. Why? Because we have been developing and building windows, doors and conservatories to the highest quality criteria for over 50 years, leaving nothing to chance: from the careful selection of materials and manufacture in our own production facilities to professional installation by trained assembly professionals – with Finstral you always get everything from a single source. You can rely on that. There's a reason why we are the Europe's most certified window manufacturer.

Always with best regards,



Florian, Joachim and Luis Oberrauch
Finstral Board of Directors



Contents

Safety instructions

Tilt-and-turn fittings: window and casement door

- Component description
- Standard handle
- Handle with push-button
- Push-down handle
- Lockable tilt-before-turn handle
- Double-sash, loose centre part
- Turn lock
- Motorised tilt-and-turn fittings
- Identifying and solving problems

Lockable pivot fittings: casement door

Locking cylinder

Fanlight

- Component description
- Handle, hand lever, crank
- Cleaning fanlight tilt windows
- Fanlight with motor

6 Sliding elements

- Parallel sliding door and window 22
- Parallel sliding-tilting door and window 23
- 8 FIN-Slide lift-and-slide door and window 24
- 9 Lift-and-slide door with motor  24
- 10 FIN-Scroll sliding door and window 26
- 11 FIN-Fold folding door 28

13 Ventilation

- 14 General information 30
-  14 Summer/winter tilt position 32
- 15 2-stage rotary opening 33
- Gap ventilation position 33
- 17 Window rebate vent PassiveVent Mini 34
- Window rebate vent PassiveVent Midi 35
- 17 Cleaning and maintenance PassiveVent 35
- Vent ventilation sash 36

19 Insect protection

- 20 Insect screen roller/pleated blinds 37
- 21 Insect screen frame 38
-  21 Cleaning 41

Roller shutter

Safety instructions	42
Belt tension	43
Wall switch	43
Radio remote control "A"	44
Radio remote control "B"	48
Identifying and solving problems	52
Further information	55

External Venetian blinds

Safety instructions	56
Wall switch	57
Radio remote control	57
Cleaning	64
Identifying and solving problems	64
Further information	65

Venetian blinds and pleated blinds

Component description	66
Safety instructions	66
Chain drive	67
Wall switch	67
Radio remote control	68
Cleaning	73
Identifying and solving problems	75

Fabric shades

Safety instructions	76
Wall switch	77
Radio remote control	77
Cleaning	77
Further information	79

Folding shutter/sliding shutter

Component description	80
Safety instructions	80
Operation	80
Cleaning of folding shutters	81

Cleaning and maintenance

Proper care	82
Cleaning in individual steps	83
Surface care	84
Annual maintenance	85

Troubleshooting

Frequently asked questions	87
Identifying and solving problems	89
Further information	91

Special equipment is marked with this symbol . For detailed information, please visit: finstral.com/manuals.

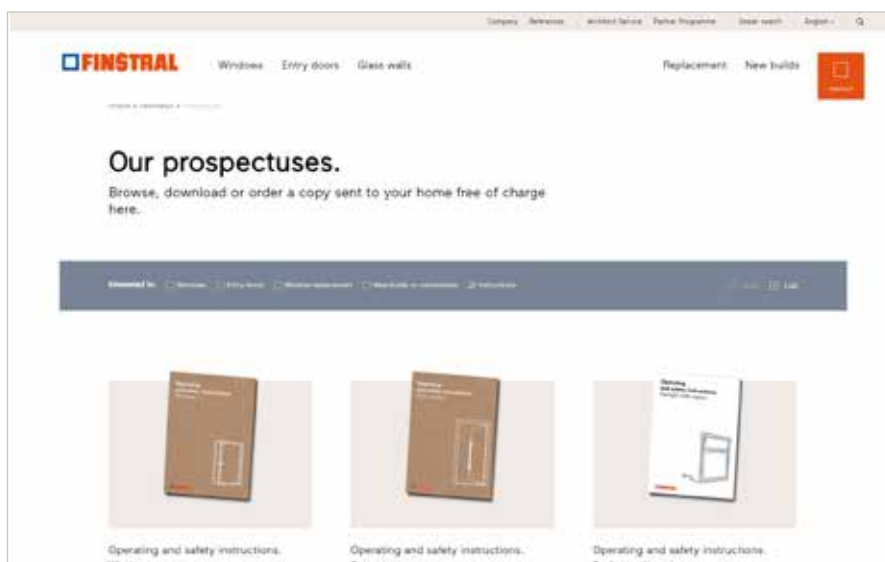

Safety instructions

- Only use the elements for the intended use and the specified purpose.
- The elements and their operating equipment may only be operated by qualified persons.
- Only operate the elements when they are in perfect condition.
- When opening, closing, cleaning and maintaining the elements, the shade and the insect screen there is a risk of falling. Do not lean out. Make sure you have a secure footing and that you are safe.
- Always be careful near open elements. Keep children and people who cannot assess dangers away from the elements.
- For all opening types, please ensure that the sash is slowly guided by hand over the entire range of movement to the absolute closed or open position.
- There is a risk of injury and entrapment when elements are tilted or open.
- Do not pull the sash frame or handle while turning the handle. Pulling the handle while turning can operate the window and cause injuries due to sudden opening of the window.
- If you want to move an open or tilted window to another position, always push it fully closed over the handle first so that the frame surrounds the sash frame. Only then turn the handle. This prevents the element from being levered out.
- Do not slam the elements. Do not tear at the element.
- Their stable construction makes the products heavy elements. There is a risk of injury in the event of careless or sudden operation. Make sure that there are no people or animals in the walking area. Also, there must be no furniture, curtains or other objects in the walking area.
- When closing the elements, make sure that no items of clothing, objects, parts of the body or persons are trapped between the sash and the frame or in the shearing and closing area. This way you avoid pinching injuries.
- With sliding elements, especially when lowering the sliding sash, make sure that there are no body parts or objects under them.
- Pay attention to the threshold height of doors. There is a risk of falling when entering and exiting.
- Always lock closed windows and doors.
- Unlocked elements in tilt position or in other ventilation positions as well as doors closed only in the latch do not fulfil any requirements regarding air tightness, driving rain tightness, sound insulation, thermal insulation and burglar resistance.
- Open and close the elements with increased caution in windy conditions. Close and lock the elements in stronger winds. Make sure that there is no draught even in your absence. In draughts or strong winds, opened or unlocked elements can open or close suddenly on their own, which can damage the product. Damage can also be caused to persons, animals or objects that are in the travel area.
- For outward opening doors, door stops are useful depending on the installation situation. They prevent the wind from opening the door and thus tearing the sash out of the hinges.
- Pay attention to the correct operation of hand levers and cranks. There is a risk of injury and entrapment.
- In frosty conditions, the elements can freeze on the outside. Do not operate the elements by force. Do not open them if they are frozen solid. After defrosting, operation is possible again.
- No additional loads may act on the elements.
- Do not place any obstacles (wedges and the like) in the opening gap between the sash and the frame.
- Make sure that the sash is not exposed to point loads or obstacles in the running area, such as e.g. roof pitches. Otherwise, the element could bump at certain points when opened and be distorted or generally damaged.
- Do not press the window or door sash against the opening edge (wall reveal).
- Do not place flames near the elements. Indirect heat sources must be at least 50cm away from the elements.
- There is a risk of people or animals bumping into the glass surface of the elements in case of glare, reflection or poor visibility.
- Float glass can break easily. There is a risk of injury due to the resulting sharp edges and glass splinters.
- All installation, assembly and disassembly work as well as maintenance and repair work may only be carried out by authorised or specially trained and qualified personnel.

- Always have defective elements checked and adjusted by qualified personnel.
- Do not make any technical changes to the components.
- Work on the mains supply may only be carried out by an authorised electrician.
- Electric motor-driven elements can squeeze body parts in and out. There is a risk of injury and death.
- Cleaning and maintenance of electronic components may only be carried out by authorised persons.
- Electrically operated elements must be designed in such a way that they do not protrude into traffic routes in buildings, either closed or open.
Openings at floor level must be secured against falling.
- In automatic mode, the drive is stopped via the limit or overload shut-off.
- Necessary work on the 230V AC mains may only be carried out by an authorised electrician.
- Electric motor-driven systems can start fires due to overheating. There is a risk of injury and death from electric shock or fire.
- Do not operate the motorised elements when people are carrying out activities on the element (e.g. cleaning etc.). Always disconnect the power supply before cleaning or maintenance work on the element.
- If a fault is detected, have the unit checked only by a specialist.
- When cleaning the drive, always make sure that no liquid gets inside the unit so that the electronics are not damaged. If a solid object or liquid gets inside the unit, stop operation immediately and disconnect the system from the mains. Then have the system repaired by qualified personnel.
- Children and animals must not play with the remote controls or wall switches. Keep remote controls out of the reach of children and animals. Children and animals could swallow parts of the remote control or change settings.
- Do not throw batteries into fire and do not insert a battery of the wrong type. There is a risk of explosion.
- Batteries are harmful to the environment and must therefore be disposed of conscientiously.
- Flammable liquids or gases may leak from batteries. Do not swallow batteries or insert them into any orifices. Seek medical attention immediately if any of the above has occurred.
- During the execution of motorised movements, control the operation and keep a safe distance until the movement is finished.
- Remember to regularly check the balancing springs and the wear of the cables (if any).
- In order to assess the potential danger that can emanate from a motorised element (window, door, shade, ventilation) and to be able to take appropriate protective measures, a risk assessment must already be prepared during the planning stage. Risk analysis provides the necessary information for risk assessment, which can be used to make decisions about the safety of the power-operated elements. Depending on the individual object and usage situation, a risk and hazard analysis must be carried out on the construction side during the planning phase, for example in accordance with our checklist "Risk assessment and hazard analysis for power-operated windows and doors" and the current Machinery Directive for the design of the safety device and installation situation.

Tilt-and-turn: window and casement door

→ Component description



Tilt position



Opening position
or rotary opening



Window in locking position

Surrounding frame

Sash frame

Glass

Handle

Hinge



Double-sash door

Surrounding frame

Sash frame

Glass

Handle

First opening sash

Second opening sash

→ Standard handle

Standard handle operation

With a standard handle, the window/casement door can be either fully opened or tilted. If your window/casement door is equipped exclusively with tilt or turn fittings, please note only the descriptions for the tilt or turn position in the following. Carry out the steps described in the order listed here. When doing so, make sure that the sash is slowly guided by hand over the entire range of movement to the absolute closed or open position.

Open

Opening position

The handle points downwards. The window/casement door is closed. Turn the window handle upwards by 90°. The window/casement door can thus be opened completely.

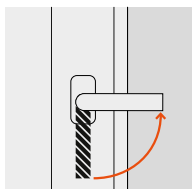

Tilt position

from the locked position

Turn the handle upwards by 180°. The window/casement door can be tilted by pulling the handle slightly.

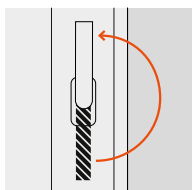

from the open position

Push it shut using the handle. Turn the handle upwards by 90°. The window/casement door can be tilted by pulling the handle slightly.

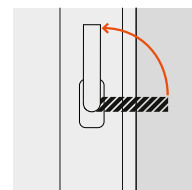

Close

from the open position

Push the fully open window/casement door closed via the handle. Turn the handle downwards by 90°. The window/casement door is closed.

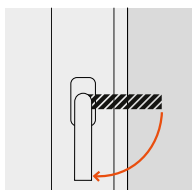

from the tilt position

Push the tilted window/casement door closed by using the handle. Turn the handle by 180° downwards. The window/casement door is closed.

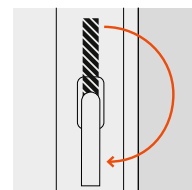

Operation lockable standard handle

Locking and unlocking is possible in the tilt position as well as in the locked position. The profile cylinder can be attached to the handle or in the rosette. The following pictures show the example of a profile cylinder on a handle.

Locking

Turn the key by 180° in the locking direction.

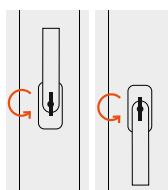

Unlocking

Turn the key by 180° in the unlocking direction.

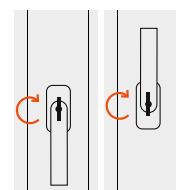

Tilt-and-turn: window and casement door

→ Handle with push-button

Operation handle with push-button

This handle allows a window/casement door to be operated by pressing a push-button located at the base of the handle. The window/casement door can be opened or tilted with it. If your window/casement door is equipped exclusively with tilt or turn fittings, please note only the descriptions for the tilt position or the turn position below. Carry out the steps described in the order listed here. When doing so, make sure that the sash is slowly guided by hand over the entire range of movement to the absolute closed or open position.

Open

Opening position

The handle points downwards. The window/casement door is closed. Press and hold the push-button with your thumb. Turn the handle upwards by 90° and release the push-button. The window can be opened completely.

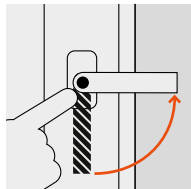

Tilt position from the shutter position

Press and hold the push-button with your thumb. Turn the handle upwards by 180°. The window/casement door can be tilted by pulling the handle slightly.

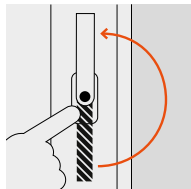

from the open position

Push the window/casement door closed by using the handle. Press and hold the push-button with your thumb. Turn the handle upwards by 90°. The window/casement door can be tilted.

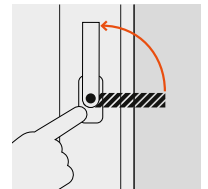

Close

from the open position

Push the window/casement door closed by using the handle. Press and hold the push-button with your thumb. Turn the handle downwards by 90° and release the push-button. The window/casement door is closed.

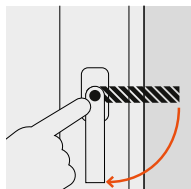

from the tilt position

Push the tilted window/casement door closed by using the handle. Press and hold the push-button with your thumb. Turn the handle downwards by 180° and release the push-button. The window/casement door is closed.

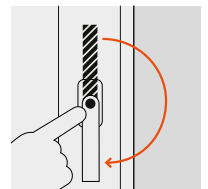

You can also release the push-button while turning the handle. The button audibly clicks out again at the next position reached. However, this does not allow you to set the tilt position directly from the closed position, as the push-button clicks out when the open position is reached.

→ Push-down handle

Operation push-down handle

A window/casement door with a push-down handle can be tilted/opened by pressing and then turning the handle. If your window/casement door is equipped exclusively with tilt or turn fittings, only observe the descriptions for the tilt or turn position. Carry out the steps described in the order listed here. Ensure that the sash is slowly guided by hand over the entire range of movement to the absolute closed or open position.

How do I operate the push-down handle correctly?

Apply pressure to the base of the handle or to the middle part of the handle. Do not apply pressure at the tip of the handle.

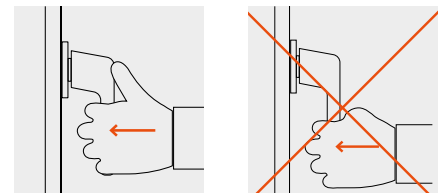

Open

Opening position

Press the push-down handle and turn it upwards by 90°. After one click you can open the window/casement door completely.

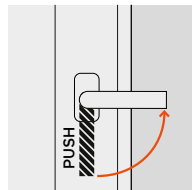

Tilt position from the shutter position

Press the push-down handle and turn it upwards by 180°. The handle clicks out as soon as you stop holding it down. The window/casement door can be tilted by pulling the handle slightly.

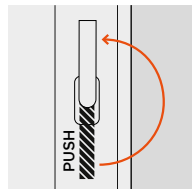

from the open position

Push the window/casement door closed by using the handle. Turn the handle upwards by 90°. The handle clicks out as soon as you stop holding it down. The window/casement door can be tilted by pulling the handle slightly.

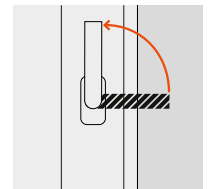

Close

from the open position

Press the open window/casement door closed. Turn the handle downwards by 90°. The handle clicks out as soon as you stop holding it down.

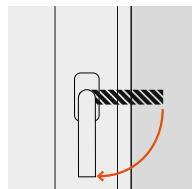

from the tilt position

Push the tilted window/casement door closed. Press the push-down handle and turn it downwards by 180°. The handle clicks out as soon as you stop holding it down.

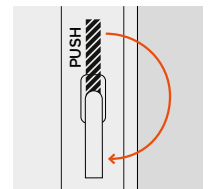

Operation lockable push-down handle

You can lock and unlock a lockable push-down handle using the profile cylinder and a key. Locking and unlocking is possible in the tilt position as well as in the locked position.

Locking

Turn the key by 180° in the locking direction.

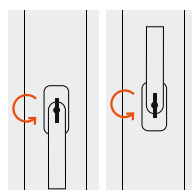

Unlocking

Turn the key by 180° in the unlocking direction.

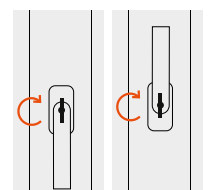

Tilt-and-turn: window and casement door

→ Lockable tilt-before-turn handle

Tilt-before-turn function

For windows/casement doors with a tilt-before-turn function, starting from the locked position, the tilt position is reached with a 90° turn and the open position with a 180° turn. In the tilt position, you can unlock the window/casement door using the key. Thus, only authorised persons can open the window/casement door. Ensure that the sash is slowly guided by hand over the entire range of movement to the absolute closed or open position.

Open

Tilt position

The window/casement door is closed. Turn the handle upwards by 90°. The window/casement door can be tilted by pulling the handle slightly. Without a key, the window/casement door can only be tilted and closed.

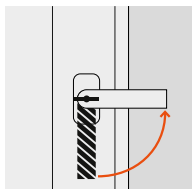

Opening position

The window/casement door is closed. Turn the handle upwards by 90° so that the tilt position is reached. Do not tilt the window/casement door, but turn the key 45° and keep it turned. Turn the handle upwards by another 90°. The window/casement door can be opened completely.

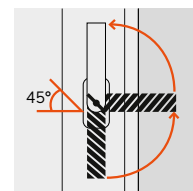

Close

from the tilt position

Push the tilted window/casement door closed. Turn the handle downwards by 90°. The window/casement door is closed.

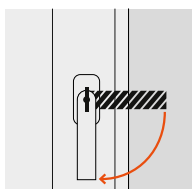

from the open position

Press the open window/casement door closed. Turn the handle downwards by 90°. The key clicks 45° in the closing direction, the handle is in the tilt position. Turn the handle another 90°. The window/casement door is completely closed.

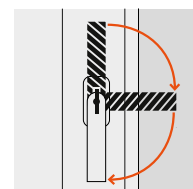

→ Double-sash, loose centre part

The first and second opening sash

The second opening sash is equipped with an unlocking lever. You can only operate it after you have opened the first-opening sash.

Safety instructions

- Do not pull the release lever suddenly.
- Do not pull the release lever in a horizontal direction, otherwise it could break off or be levered out.

Operation

First opening sash

Opening position

The handle points downwards. The first opening sash is closed. To open it, turn the handle upwards by 90°. For more detailed information, see the descriptions of the opening position for the respective handles, see pages 9–12.



Tilt position

To tilt the first-opening sash, turn the handle upwards by 180°. For more detailed information, see the descriptions of the tilt position for the respective handles, see pages 9–12.



Second opening sash

Opening position

Fold the release lever upwards by approx. 45°. The second opening sash can be opened.

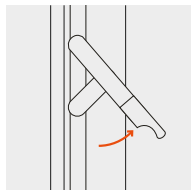

No tilt position

The tilt position is not possible with a second-opening sash.



Closing position

Push the release lever down until it is vertical again. Only after the second opening sash is locked, the first opening sash can be locked.

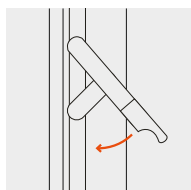

Tilt-and-turn: window and casement door

→ Turn lock

Operation turn lock

The turn lock is located on the lower side of the sash frame. The window/casement door can only be tilted, but not opened. Unlocking the turn lock and fully opening a window/casement door is only possible with a key. This means that only authorised persons can open the window.

Active turn lock

The locking is locked, the window/casement door can be tilted but not opened.



Decoupled turn lock

Turn the key 90° in the opening direction. The window/casement door can be opened.



→ Motorised tilt-and-turn fittings



Information on operating the motorised tilt-and-turn fittings with a wall push-button or remote control

All information on operating a motorised tilt-and-turn fittings with a wall push-button or with a remote control can be found at finstral.com/manuals.

→ Identifying and solving problems

Problem	Solution
The sash lifter is stuck.	Have the sash lifter replaced.



Note on common operating errors

Handle operations with maloperation lock are standard at Finstral. They prevent the handle from turning when the window is tilted and open/when the casement door is tilted and open, which would cause the window to unhinge.

Nevertheless, the sash frame can be levered out if you tilt the fully open window/casement door or want to fully open the tilted window/casement door and operate the handle before the window sash has been completely pressed into the frame. Therefore, always observe the order: first push the window/casement door closed and then operate the handle.

Remedy of the operating error

If the error just described has happened to you, read here how you can fix it yourself. If in doubt, contact the technical service of the installation company.

Safety instructions

- Make sure that you do not trap any body parts, persons or objects during the levering-in process. There is a risk of injury.
- There is a risk of falling when levering in. Always be aware of your safety.
- Children or persons with physical or mental disabilities must not lever in the window.
- Only lever in small or easily accessible windows.

Levered sash: transition from tilt position to locked position

1. The sash is obviously tilted, but the handle indicates the locked position. The window cannot be closed.



2. Do not force the window shut. The sash or fitting could be damaged. Leave the window tilted and turn the handle 90° in the direction of rotation.

The sash is levered out. For the further procedure see from point 1 at “Levered sash: transition from tilt position to open position” (see page 16). Follow all the steps described therein in the order given.



Tilt-and-turn: window and casement door

→ Identifying and solving problems

Levered sash: transition from tilt position to open position

1. The sash is levered out at the top corner. The handle indicates the opening position.



2. Carefully press the upper, levered-out part of the sash into the corner. The bolt continues to butt against the shear.



3a. At a window: operate the sash lifter so that it is vertical (it must not form an angle) and hold it in this position.



3b. At a casement door: operate the sash lifter with your foot so that it is vertical (must not form an angle) and hold it in this position.



4. While holding the sash lifter in the vertical position, turn the handle 90° in the direction of rotation so that it indicates the tilt position.



5. Press the sash completely into the upper corner of the frame and continue to hold the sash lifter in a vertical position.



6. While holding the sash lifter in the vertical position, turn the handle 90° in the closing direction so that it indicates the opening position. The window is functional again.



Levered sash: transition from open position to tilt position

In this case, follow steps 5, 3 and 6 for "Levered sash: transition from tilt position to open position" in the sequence given here.

Lockable pivot fittings: casement door

Opening position

The handle is horizontal. With the door locked, operate the key first. Push down the handle of the unlocked door. The door can be opened.

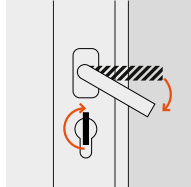

Locking

Pull the handle all the way up and move it back down. Lock the door using the key.

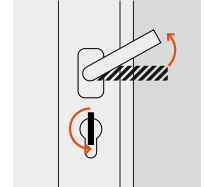

Tilt position

The tilt position is not possible with a lockable swing door.

Troubleshooting for swing door

Error	Cause	Rectification
The swing door cannot be locked.	The handle was not completely pulled up to the base.	Pull the handle upwards to the base until the key can be turned perceptibly.

Locking cylinder

Standard cylinder

A classic standard cylinder can be locked on both sides. This allows you to lock and unlock the door both from the outside and inside, even if a key is inserted on the other side of the door (emergency and danger function).

Cylinder security level 1

A level 1 security cylinder is operated with a reversible key. It enables intuitive operation, offers optimum drill protection and can be locked on both sides. This allows you to lock and unlock the door both from the outside and inside, even if a key is inserted on the other side of the door (emergency and danger function). A security card is supplied with this security cylinder, which is used to reorder replacement keys.

Cylinder security level 2

A level 2 security cylinder is operated with a reversible key. It enables intuitive operation, provides particularly effective protection against manipulation thanks to the first-class drilling and pulling protection, and can be locked on both sides. This allows you to lock and unlock the door both from the outside and inside, even if a key is inserted on the other side of the door (emergency and danger function). A security card is supplied with this security cylinder, which is used to reorder replacement keys.

Locking cylinder

Reordering the security cylinders

The standard cylinder is installed in the element on delivery. The security cylinders, on the other hand, are supplied loose in their original sealed packaging for confidentiality reasons. A security card is always included in the packaging. Please store it in a safe place as it will be used to re-order replacement keys. No replacement key can be made without the security card. If you need to reorder a key and the security card can no longer be found, the cylinder must be replaced.

Cylinder replacement

You can carry out the cylinder replacement on almost all lockable elements that can be found in this instruction manual. You cannot replace the cylinder yourself only for lockable windows where the profile cylinder is permanently installed in the handle. In case of a defective profile cylinder in the handle, contact the technical service of the installation company.

1. When replacing the cylinder, ensure that it is seated straight and perpendicular to the sash. To remove the cylinder, unscrew the cylinder screw with a hand screwdriver.



2. Then insert the key into the profile cylinder and turn the key 15°–20°. The cylinder can now be gently pulled out.



3. Insert the new cylinder. For this purpose, the cylinder must move smoothly and be seated in the fitting with as little tension as possible. If you have a security level 2 cylinder, make sure that the parts of the profile cylinder are on the intended side (outside or inside). The outside is marked.



4. Tighten the cap screw with a manual screwdriver with medium force. When pushing the cylinder in, make sure that no pressure is exerted on the outer rosette.

Fanlight

→ Component description



Fanlight

→ Handle, hand lever, crank

Operation with handle

The handle can be fitted either on the top, right or left side of the skylight. There is also the version with two handles located on the right and left side of the skylight. Below is an example of how to operate a skylight that has a handle on both sides. The system is transferable to the other case studies.

Open

Turn the handles right and left 180° in the direction of rotation. The fanlight can be tilted.

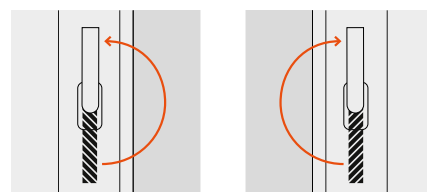

Close

Press the tilted fanlight closed. Turn the handles right and left 180° in the direction of closure. The fanlight is closed.

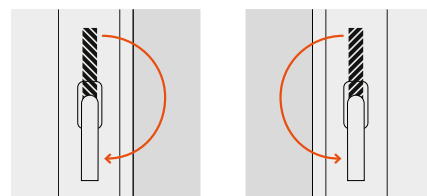

Operation with hand lever

Here you will learn how to operate a fanlight with a hand lever.

Open

Fold the hand lever down from the top. The fanlight is tilted during operation of the hand lever.

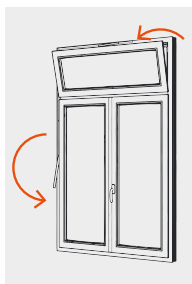

Close

Fold the hand lever upwards from below. The fanlight is closed during operation of the hand lever.



Operation with crank

Here you will learn how to operate a fanlight with a crank. The crank is either permanently mounted or can be hooked in and out as required.

Open

Move the crank to the position shown and crank in the opening direction. The fanlight is tilted.

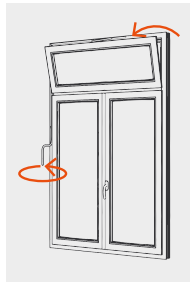

Close

Move the crank to the position shown and crank in the closing direction. The fanlight is closed.

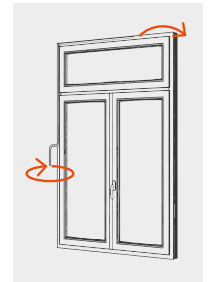

→ Cleaning fanlight tilt windows

Clean the fanlight with a cloth dampened with mild soapy water or washing-up liquid.

Maintenance and inspection of the fanlight tilt window and the parts of fittings must be carried out at least once a year. To do this, you need to release the security stay and fold down the fanlight.

Caution: there is a risk of injury due to the weight of the heavy element. This work may therefore only be carried out by qualified personnel. Contact the technical service of the installation company. Observe the safety instructions.

→ Fanlight with motor



Information about the fanlight with motor

All information and important instructions for operating a fanlight with motor can be found at finstral.com/manuals.

Sliding elements

→ Parallel sliding door and window

Operation

Here you will learn how to operate a parallel sliding element. Ensure that the sash is slowly guided by hand over the entire range of movement to the absolute closed or open position.

Open

The handle points downwards. The door is closed. Turn the handle upwards by 90°. Pull the door slightly towards you. The sash extends slightly in your direction. At the bottom, the mechanism clicks out audibly. Slide the sash in the opening direction.

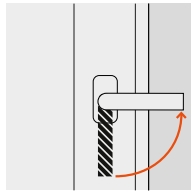

Close

The door is open. The handle is turned by 90°. Slide the door shut. The mechanism locks into the end stop. Push the door shut. When the door is fully closed, turn the handle 90° downwards. The door is locked.

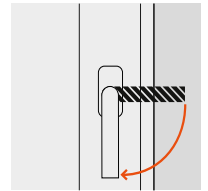

Identifying and rectifying the problem

If the element cannot be closed, here is a possible cause and the solution of the problem.

Error	Cause	Rectification
The element cannot be closed.	The handle was turned to the locking position before the element was fully pressed shut.	Turn the handle by 90° in the opening direction so that the open position is reached. Press the element closed and turn the handle by 90° in the closing direction.

→ Parallel sliding-tilting door and window

Operation

Here you will learn how to operate a parallel sliding door with tilt function. Ensure that the sash is slowly guided by hand over the entire range of movement to the absolute closed or open position.

Tilting

from the shutter position

The handle points downwards. The element is closed. Turn the handle upwards by 180°. The element can be tilted.

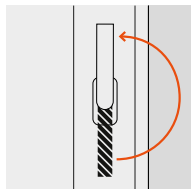

To close the element again, press the tilted element closed and turn the handle 180° downwards. The element is closed.

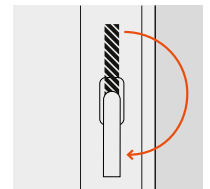

from the open position

The element is open. The handle is turned by 90°. Push and press the element closed. When the element is fully pressed shut, turn the handle upwards by 90°. The element can be tilted.

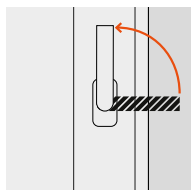

If you want to return the element from the tilt position to the open position: press the element closed and turn the handle 90° downwards. The element can be opened.

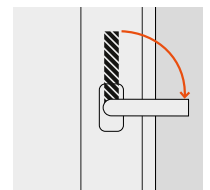

Lockable parallel sliding or parallel sliding-tilting element

Locking and unlocking is possible in the tilt position as well as in the locked position.

Locking

Turn the key by 180° in the locking direction.

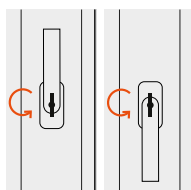

Unlocking

Turn the key by 180° in the unlocking direction.

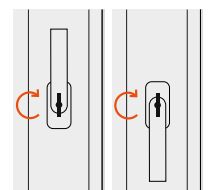

Identifying and rectifying the problem

If the element cannot be closed, you will find a possible cause and solution to the problem here.

Error	Cause	Rectification
The element cannot be closed.	The handle was turned to the locking position before the element was fully pressed shut.	Turn the handle by 90° in the opening direction so that the open position is reached. Press the element closed and turn the handle by 90° in the closing direction.

Sliding elements

→ FIN-Slide lift-and-slide door and window

Component description

Here you can see a FIN-Slide lift-and-slide door with the description of the individual components.



Soft-Stop

The soft-stop function causes the lift-and-slide element to slow down shortly before it closes completely and must be gently pushed shut manually. This prevents the element from being damaged by being pulled shut too quickly.

Four-piece FIN-Slide with loose centre part

The operation of a four-part lift-and-slide door with loose centre part is identical to the lift-and-slide door without loose centre section. Please note, however, that with this version the main sash must be operated first when opening and the second sash first when closing.



Operation with handle

Here you can read all the information that is important for operating a FIN-Slide lift-and-slide element. Ensure that the sash is slowly guided by hand over the entire range of movement to the absolute closed or open position. Take particular care when lowering the lift-and-slide door sash to ensure that there are no body parts or objects underneath.

Open

Turn the handle by 180° downwards.
The lift-and-slide element lifts up and can be opened.

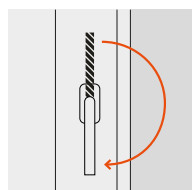

Close

Push the element completely closed.
Then turn the handle upwards by 180°. The lift-and-slide sash lowers.
The element is completely closed.

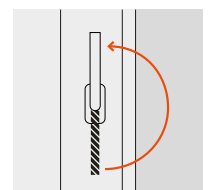

Locked gap ventilation position

Open the sliding sash by a gap (approx. 1 cm) and turn the handle upwards by 180°. The element is open a crack and remains locked in this position.

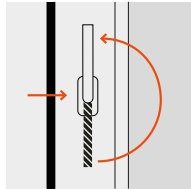

If you want to close the element or open it further, turn the handle 180° downwards. The element is operable again.

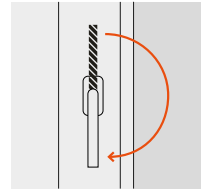

Lockable lift-and-slide door

You can lock and unlock a lockable lift-and-slide door using a profile cylinder and a key.

Locking

Turn the key by 180° in the locking direction.

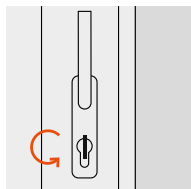

Unlocking

Turn the key by 180° in the unlocking direction.

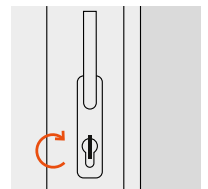

Operation with handle shell or handle strip

On the outside, the lift-and-slide door has either a handle shell or a handle strip. Both are quite easy to operate by hand. Ensure that the sash is slowly guided by hand over the entire range of movement to the absolute closed or open position.



Handle shell



Handle bar

→ Lift-and-slide door with motor



Operation with motor

For more information and important notes on the FIN-Slide motorised lift-and-slide door, please visit finstral.com/manuals.

Sliding elements

→ FIN-Scroll sliding door and window

Component description

Here we show a FIN-Scroll sliding window with all important components.



Operation with handle

Here you will learn how to operate a FIN-Scroll sliding element with one handle. Ensure that the sash is slowly guided by hand over the entire range of movement to the absolute closed or open position.

Open

The handle points downwards. The element is closed. Turn the handle upwards by 90°. The element can be opened.

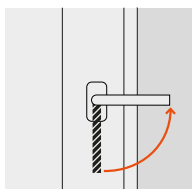

Close

Push the open element completely closed. Turn the handle downwards by 90°. The element is closed.

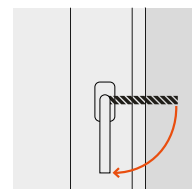

Operation with bow-shaped handle

Here you will learn how to operate a FIN-Scroll sliding element with a bow-shaped handle. Ensure that the sash is slowly guided by hand over the entire range of movement to the absolute closed or open position.

Opening position

The bolt is directed downwards by 45° starting from the horizontal alignment. The element is locked. Turn the bolt upwards by 90°. The element can be opened.

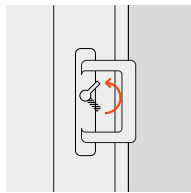

Close

Push the open element completely closed. Turn the bolt 90° downwards. The element is locked.

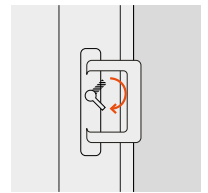

Operation with lockable bow-shaped handle

You can lock and unlock a FIN-Scroll sliding element with a lockable bow-shaped handle using a profile cylinder and a key.

Locking

Turn the key by 180° in the locking direction.

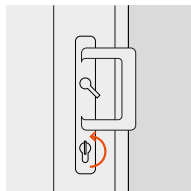

Unlocking

Turn the key by 180° in the unlocking direction.

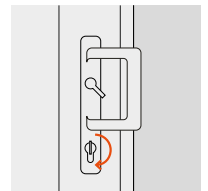

Operation with handle shell

You can easily operate the handle on the outside with your hand. Ensure that the sash is slowly guided by hand over the entire range of movement to the absolute closed or open position.



Sliding elements

→ FIN-Fold folding door

Component description

Here we show a three-part FIN-Fold folding door with all important components.



Operation

Here you can find out how to operate a FIN-Fold folding door. In general, when operating folding doors, always make sure that you make slow movements. Increased caution against entrapment injuries is advised.

Folding door 2+2-parts

Opening position

The handle points downwards. The folding door is closed. Turn the handle upwards by 90° and pull the handle to slide the folding door package open. When the folding door package is slightly open, you can support the sliding with the second hand. Repeat the same procedure with the second folding door package.

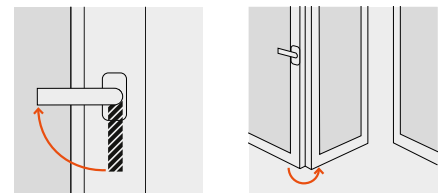

Closed position

When closing, first pull one folding package towards the centre with both hands. Then close the folding package completely by pressing the handle. Turn the handle downwards by 90°. Repeat the same procedure for the second folding package.

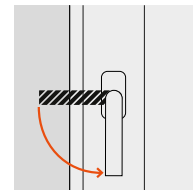

Folding door 3-piece

Opening position

The folding door is locked. Turn the handle of the first-opening sash by 90° upwards. Open the first opening sash completely by 180° until it engages with the second sash. Now turn the second handle to the open position and pull the handle to push the folding package to the side. With the second hand you can support the pushing.

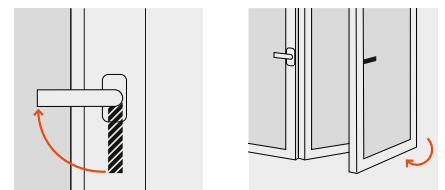

Closed position

To close, repeat the opening procedure in reverse order.

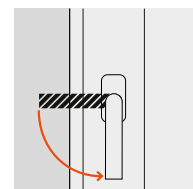

Ventilation

→ General information

Why should I ventilate?

A household of three to four people produces an amount of water of several litres every day through the breathing process alone and through cooking, bathing or via indoor plants. If the moisture cannot escape from the rooms, it condenses on the walls and windows. Condensation forms – the perfect breeding ground for mould. To improve living comfort and avoid condensation, it is therefore necessary to ventilate regularly. This way you avoid too high humidity and thus mould growth. Not only too high, but also too low room humidity can lead to health problems. Even with low room humidity, it is therefore advisable to ventilate to avoid dry air in the interior.

How do I ventilate properly?

Finstral windows seal the living space very well due to their high-quality construction and thus offer high thermal and sound insulation. We recommend opening the windows fully for 15 minutes at least once a day in the morning (shock ventilation). This allows steam and moisture to escape with little loss of room heat. Walls or furniture do not cool down during this short period of time. In a house with several connected floors, the warm air rises to the upper floors. Therefore, ventilation must be carried out more frequently on the upper floors.

The ideal temperature and indoor humidity

The ideal temperature in a living room is 20 degrees Celsius. The optimum room humidity is between 40% and 60%. A simple hygrometer can be used to measure the humidity.

New building

Fresh building materials release moisture – the so-called residual building moisture. That is why it is important to regularly shock-ventilate new buildings three to four times a day for 10 to 15 minutes right from the start.

Renovation and window replacement

When replacing windows, make sure that your new windows and doors are tighter and insulate better. This means: it needs to be aired more regularly. But don't worry – energy loss through more frequent ventilation is far lower than the additional energy consumption you had through old and leaky windows and doors.

Ventilation methods

Shock ventilation

You can shock ventilate by opening the window fully.

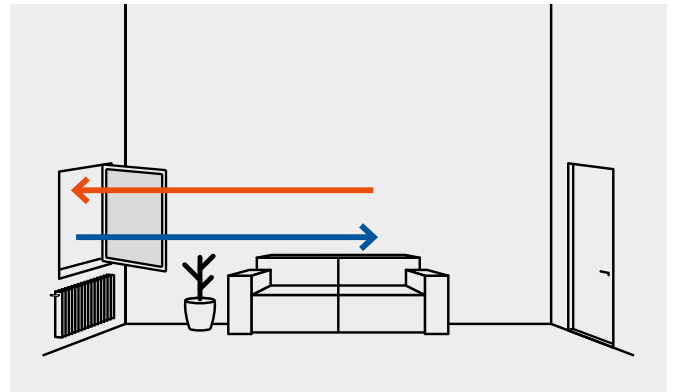

Cross ventilation

Cross-ventilation is when you open the window and door at the same time and there is draught. Please note that cross-ventilation may cause a strong draught and windows and doors may close suddenly on their own.

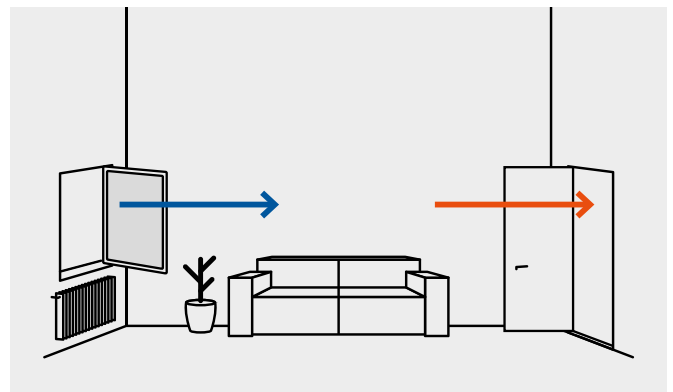

Continuous ventilation

If the window is only tilted, continuous ventilation occurs. In this case, however, the ventilation is not as effective as with the other two ventilation methods, where a lot of fresh air flows into the interior in a short time. If you put the windows in the tilt position, you can also partially ventilate rooms. But be careful: in rooms with high humidity (kitchen, bathroom, bedroom), do not tilt the windows when temperatures are below zero. This prevents the cold outside air from cooling the walls next to the windows, allowing moisture to settle and mould to develop. Please note that tilted windows and doors are not burglar-proof.

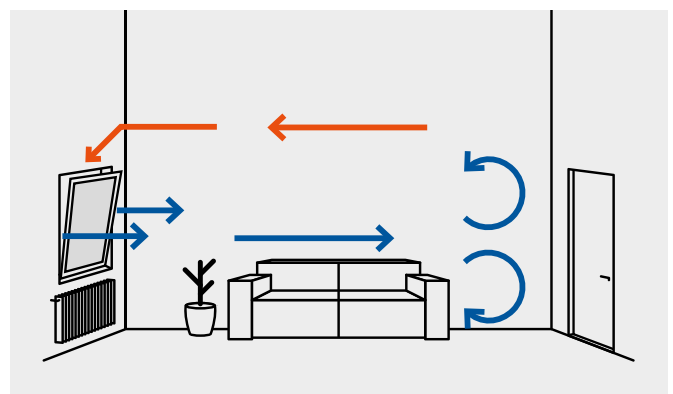

Ventilation

→ Summer/winter tilt position

Description

With the summer/winter tilt position, you can adjust the width of the tilt opening by hand: up to 17cm in summer, 4cm in winter (depending on the size of the window). The lever required for this is located in the upper corner area of the window on the handle side.

Setting the winter tilt position

If you want to set the winter tilt position, proceed as follows.

1. Open the window completely. The winter tilt lever is located in the upper part of the frame.



2. Pull out the upper part of the lever in a horizontal direction and keep it extended.



3. While the upper part of the lever is extended, turn the lever upwards by 180°. It clicks audibly into place.



4. Close and tilt the window. The winter tilt position is set.



Setting the summer tilt position

If you want to set the summer tilt position, proceed as follows.

1. Open the window completely.



2. Pull out the upper part of the lever in a horizontal direction and keep it extended.

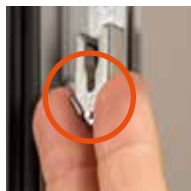

3. While the upper part of the lever is extended, turn the lever 180° downwards. It clicks audibly into place.



4. Close and tilt the window. The summer tilt position is set.



→ 2-stage rotary opening

Function 2-stage rotary opening

It may not be possible to tilt very tall or unusually shaped windows. The 2-step rotary opening offers a solution. Instead of the usual vertical tilt ventilation opening, the ventilation takes place via a horizontal, fixed rotary opening.



Rotary opening position

Turn the handle by 180° in the opening direction. Then gently pull the handle. The element opens by a crack. Turn the handle by 180° in the locking direction to fix the 2-step rotary opening.

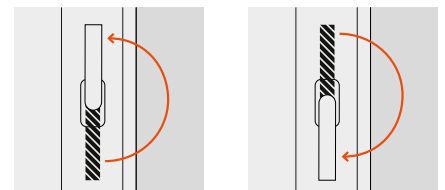

Closed position

When the element is in the fixed 2-step rotary opening, turn the handle by 180° in the opening direction. Press the element completely shut so that the frame completely surrounds the sash frame. Then turn the handle by 180° in the direction of closure. The element is locked.

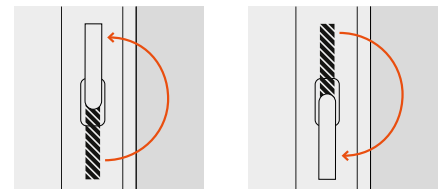

→ Gap ventilation opening

Function gap ventilation opening

With the gap ventilation opening, a tilt gap ventilation of up to approx. 5mm is possible with a handle position of up to 135°.

Tilt-gap ventilation

The more you turn the handle upwards starting from the opening position (90° angle), the more the tilt-gap ventilation opens.

Tilt opening

If the handle is turned further into the tilt position (180° angle), the window can be tilted normally.

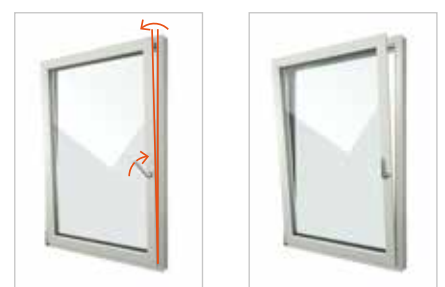

Tilt-gap ventilation

Tilt opening

Ventilation

→ Window rebate vent PassiveVent Mini

Safety instructions

If you own a PassiveVent Mini or PassiveVent Midi window rebate vent, pay attention to the following safety instructions.

- The volume flow can be reduced depending on the profile system, geometry, or the blockage of the rebate space by parts of the fittings.
- Make sure the airways are clear. Make sure that the air can flow in and out of the air inlet and outlet openings unhindered. There should be no textiles, papers or similar hanging over the openings. Do not place any objects in front of or next to the appliance and do not insert any objects into the openings of the appliance.
- Under extreme climatic conditions, the following impairments may occur: condensation (this is a physical effect, not a defect), restrictions in function or increased noise.
- The window ventilators can support dehumidification of the dwelling depending on the outdoor conditions, but are not suitable for targeted dehumidification (e.g. drying of new buildings or concealment of construction defects).
- In the event of a disaster, the ventilators are to be taped off or closed via the closing option, if present.

Component description

The PassiveVent Mini is attached to the side of the surrounding frame on the hinge side. With the optional turning lock, the air supply can be opened or closed manually. However, 100% hundred percent sealing is not guaranteed.

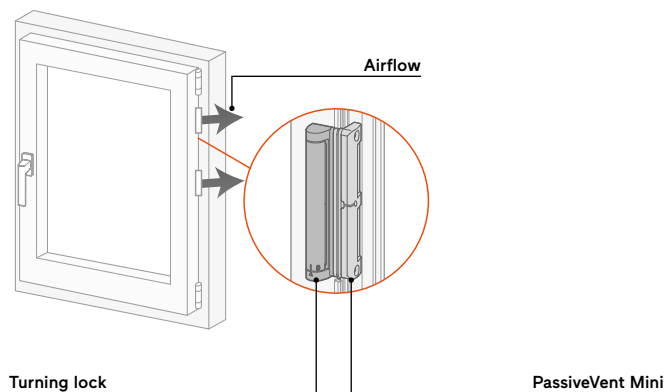

Operation

Here you can find out how to operate a PassiveVent Mini window rebate ventilator.

Open

Turn the mechanism so that the arrow points to "I". The air can now flow through.

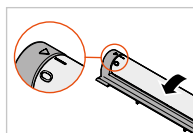

Close

Turn the flap into the rounding so that the arrow points to "0". The turning mechanism is closed.

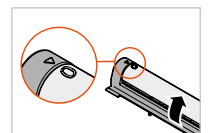

→ Window rebate vent PassiveVent Midi

Safety instructions

If you have a window rebate ventilator PassiveVent Midi, pay attention to the safety instructions on the previous page (under “Window rebate ventilator PassiveVent Mini”).

Component description

The PassiveVent Midi is fitted at the top centre of either the sash or the frame. A PassiveVent Midi attached to the frame is always without humidity control and sound insulation module. On the sash frame, it can optionally be equipped with humidity control or with humidity control and sound insulation module.

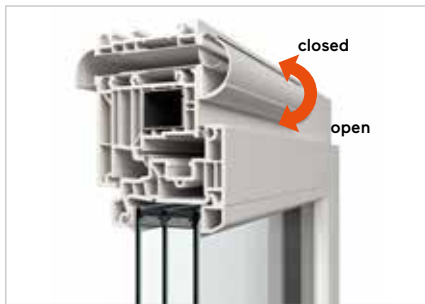

PassiveVent Midi frame variant

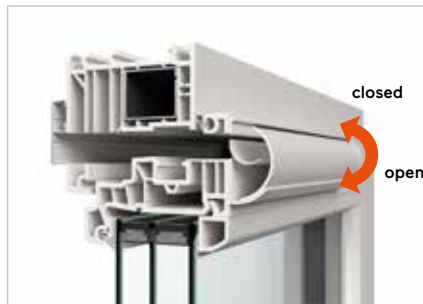

PassiveVent Midi sash frame variant



PassiveVent Midi sash frame variant with humidity control



PassiveVent Midi sash frame variant with humidity control and sound insulation module

Operation

Operate the lever to open and close the shutter.

→ Cleaning and maintenance PassiveVent

- Do not use any aggressive or solvent-based cleaning agents or sharp-edged objects, otherwise the housing surfaces may be damaged.
- Never clean the fan with a high-pressure cleaner or a steam jet.
- Clean the fan at regular intervals several times a year.
- Clean the surface with a cloth dampened with mild soapy water or a mild detergent.
- If necessary, also clean the window rebate and the airways.

Ventilation

→ Vent ventilation sash

Component description

Here you can see a ventilation sash vent from the outside. It is not obvious whether the sash is open on the inside or not.



Lamellae Vent ventilation sash

Operation

In the following, you will read how to operate the ventilation sash vent.

Open

Turn the handle 90° in the opening direction. The door of the ventilation sash can be opened.

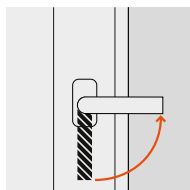

Close

Properly close the open door of the ventilation sash. Turn the handle by 90° in the direction of closure. The door is locked.

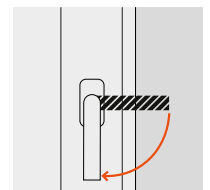

Tilt position

A tilt position is not possible.

Insect protection

→ Insect screen roller/pleated blinds

Safety instructions

The following safety instructions apply to both the insect screen roller blinds/pleated blinds and the insect screen frame.

- Only use insect screens for their intended use.
- Insect screens serve as insect protection for open windows or doors. The insect screen is not suitable as a holding or fall protection. A closed insect screen does not protect against falling out of a window or door.
- There is a risk of falling when opening, closing, removing, inserting, cleaning and maintaining the insect screen. Do not lean out of the window.
- The insect screen may freeze in frosty conditions. Do not operate the insect screen by force. Do not operate the insect screen if it is frozen. After defrosting, operation is possible again.
- No additional loads may act on the insect screen.
- The guiding of the insect screen must not be obstructed. Make sure that there are no obstacles blocking the travel area and that the guide rails allow free travel.
- People, children and animals can accidentally bump into the insect screen and damage it.
- Do not kick against or into the screen.
- The insect screen only provides protection against insects and small animals. If the wind speed exceeds 20km/h, the insect screen must be retracted. A movable insect screen should always be operated with slow movements.

Operation

Here you can learn everything about the professional operation of insect screen roller blinds and pleated blinds.

Insect screen roller blinds for windows (vertical)

The insect screen roller blinds can be rolled up and down vertically.

Pull the cord in the middle to lower the blinds. Grip the side grip shells with both hands and, in the end position, press the end bar down slightly until you hear a click.

To unlock the blinds, press the end slat slightly downwards from above. Hold the blinds by the cord and let them move upwards over the cord in a controlled manner.

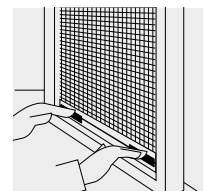

Insect screen roller blinds for doors (horizontal)

The laterally sliding insect screen roller blinds is equipped with a guide rail at the bottom and with a net that can be positioned horizontally as desired and continuously. To open, pull the end strip slightly to the side (horizontal direction).

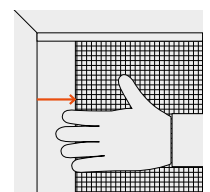

Insect screen pleated blinds for doors

To open, press the end strip slightly to the side (horizontal direction).

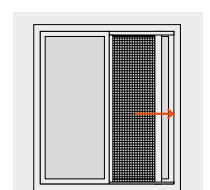

Insect protection

→ Insect screen frame

Safety instructions

Observe the safety instructions that you will find on the previous page (under insect screen roller blinds/pleated blinds).

Differentiation type 1, 2 and 3

Finstral offers three different types of insect screens. Below you can see an overview:

Type 1

Two brackets are located on the top and bottom frames of the insect screen respectively. There is a handle lug on the side.

Type 2

Two fixed brackets are located on the lower frame of the insect screen. On each of the lateral edges, at the same height, there is a movable, rotatable holder and a handle lug.

Type 3

Casement door: there are three fixings on the right side of the insect screen frame. On the left side there is a handle lug on the inside and a pull handle on the outside.

Operation type 1

Here you can find out how to insert and remove a fixed insect screen type 1 for windows made of PVC-U plastic.

Insert insect screen frame (type 1)

Position the fixed insect screen at the bottom and press it against the window frame at the top until it clicks into place. Fix the insect screen frame with the brackets (top and bottom).



Bracket

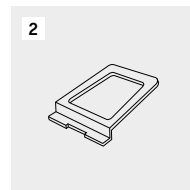

Handle lug

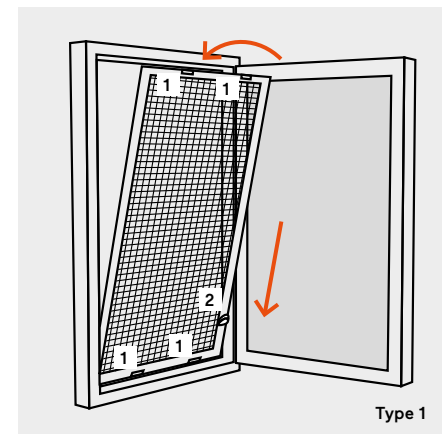

Remove insect screen frame (type 1)

Pull the insect screen frame inwards by the lower, side handle lug and release the two lower brackets. Hold the insect screen firmly and release the two upper brackets by pulling the frame down and towards you.

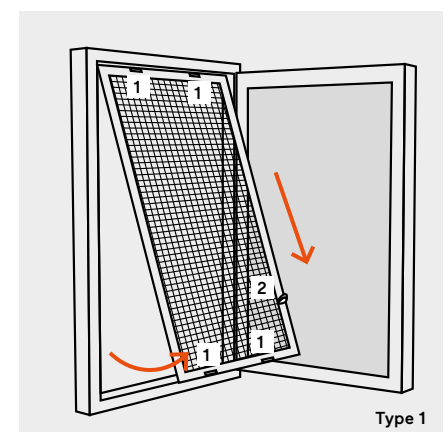

Operation type 2

Here you will learn how to insert and remove a fixed type 2 insect screen for PVC-U windows.

Insert insect screen frame (type 2)

Hold the frame by the two handle lugs and guide it diagonally outwards through the window opening. Lower it so that the two brackets at the bottom of the window frame are fixed and pull the insect screen frame towards the window frame. To fix it in place, turn in the two movable brackets on the side.

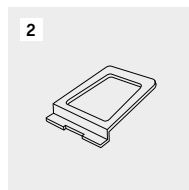

Handle lug

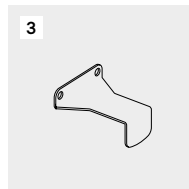

Bracket (hook)

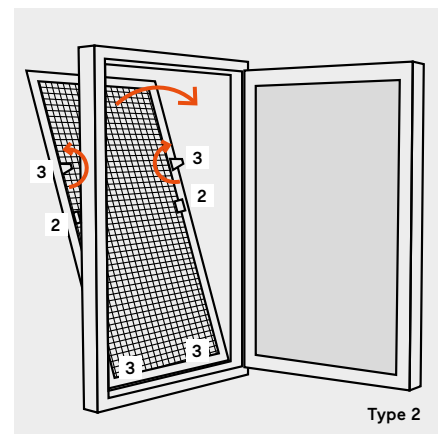

Remove insect screen frame (type 2)

Loosen the two flexible brackets. Hold the insect screen frame by the two handle lugs on the side and carefully push it outwards. Guide the insect screen frame diagonally inwards through the window opening.

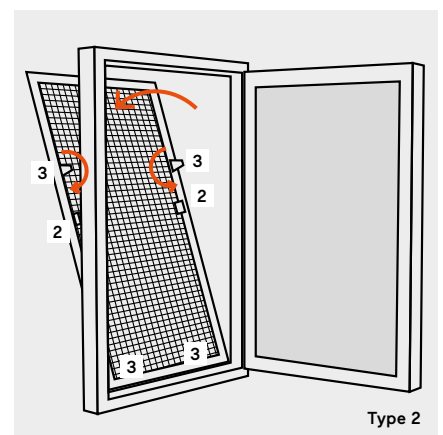

Insect protection

→ Insect screen frame

Operation type 3

Here you will learn how to insert and remove a fixed type 3 insect screen for PVC-U casement doors.

Insert insect screen frame (type 3)

Three hinges are mounted on the door frame. Take the insect screen frame by the sides with both hands and insert the three side fixings into the three bands from top to bottom. Be careful not to move the insect screen at an angle, but vertically downwards. You can open and close the insect screen from the outside by operating the handle, and from the inside via the handle lug.

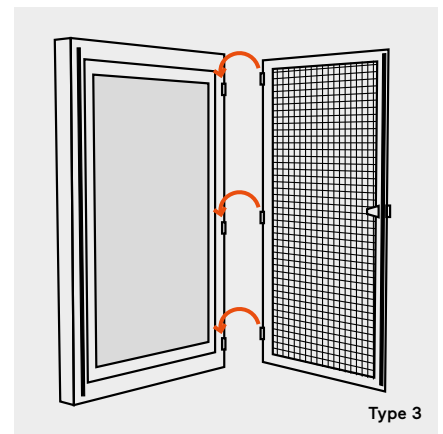

Remove insect screen frame (type 3)

Open the insect screen and take it by the sides with both hands. Carefully lift it upwards so that the three fixings come off the straps. Make sure that you do not lift the insect screen frame at an angle, but vertically upwards.

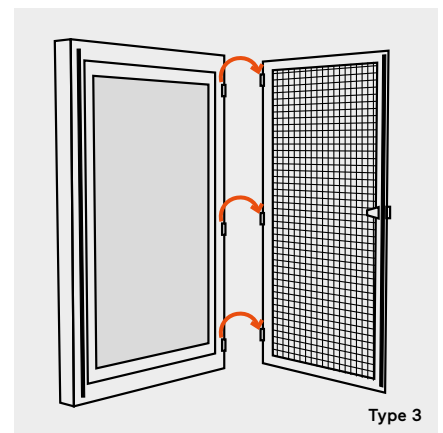

→ Cleaning

Check the net at least twice a year, once in spring and once in autumn. To clean the net, you can vacuum the dust or clean it with lukewarm water and a soft cloth. Do not use solvents, ammonia or hydrocarbons. Allow the net to dry completely before rolling it up. Should the covering come loose from the holder, it can be grasped with both hands and from both sides and hooked back in.

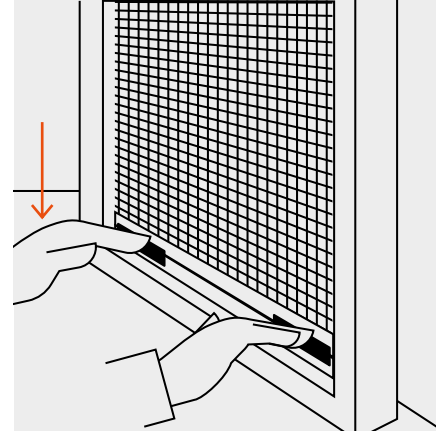

The bottom track should be kept free of coarse dirt. If twigs or leaves are left on the travel rail, there is a risk that they will be pulled into the mechanism when the insect screen is opened and get stuck there. Therefore, you should regularly clean the covering as well as the travel rail with a vacuum cleaner on a low setting.

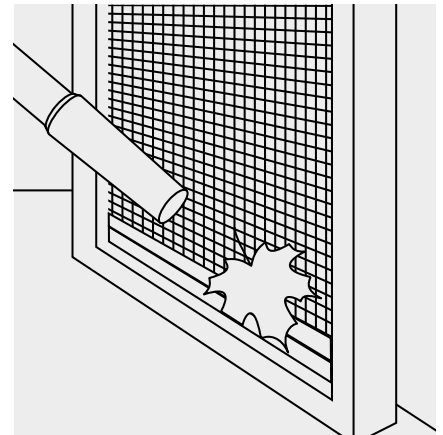

Roller shutter

→ Safety instructions

- Only use the roller shutter for its intended use.
 - The roller shutter is a closure that serves as privacy and sun protection in front of a window or door. The roller shutter is not suitable as a holding or fall protection device. A closed roller shutter does not protect against falling out of the window or door.
 - There is a risk of falling when opening, closing, cleaning or maintaining the roller shutter. Do not lean out of the window.
 - Due to its stable construction, the roller shutter is a heavy element. There is a risk of injury in the event of careless operation.
 - Close your windows in strong winds. Make sure that there is no draught even in your absence. Closed roller shutters do not withstand every wind load when the window is open. Note that the specified wind load is only guaranteed when the window is closed.
 - When using roller shutters as sun protection we recommend that you do not close them completely to ensure sufficient ventilation.
 - The roller shutter may freeze in frosty conditions. Do not operate the roller shutter by force. Do not open and close the roller shutter if it is frozen. After defrosting, operation is possible again.
 - Do not obstruct the lowering of the roller shutter. Make sure that there are no obstacles, people or animals in the running range of the roller shutter and that the free running of the roller shutter rails is guaranteed.
 - There is a risk of injury when closing or opening shutters. Do not reach into the travel area of the roller shutter or into the roller shutter rails. Make sure that no persons or animals are in the travel area of the roller shutter when it is operated. Do not push up the roller shutter without operating the drive. This could cause malfunctions.
 - Do not operate the shutter when adjustments or repairs are to be made to it.
 - To solve problems or carry out repairs, contact qualified technical personnel only.
 - Prevent items of clothing, objects or body parts from being caught by the unit.
 - No additional loads may act on roller shutters.
 - Do not push the roller shutter up or pull it down by hand.
- Additional instructions for motor-operated roller shutters with automatic control:
 - If a roller shutter is installed in front of the only access to your balcony or terrace, which is connected to an automatic sensor system, you can lock yourself out. Switch off the automatic system when you are on the balcony or terrace to avoid being locked out.
 - Switch off the automatic system of motor-operated roller shutters with automatic switching if there is a risk of freezing. Exception: roller shutter drives equipped with overload protection or obstacle detection.
 - We recommend an emergency power supply especially in areas with frequent mains failures. This way you can prevent a malfunction of the roller shutter due to a power failure.
 - Do not let children or animals play with the controls such as remote controls or switches of the roller shutter. Keep remote controls away from children and animals.

→ Belt tension

- When lowering the roller shutter, operate the roller shutter belt slowly in the last third. The roller shutter must not hit the top by force. Also operate the roller shutter belt slowly in the last third when pulling it up. The roller shutter belt is automatically wound up in the winder housing. Never let go of the belt and do not operate it suddenly.
- Always pull the roller shutter belt evenly and vertically out of the winder housing. If you do not pull it out of the housing vertically, the belt may warp, wear out and cause malfunctions.

→ Wall switch

The motor switches off automatically in the upper and lower end positions. Different variants of switches are available.

Rotary or push-button

Pressing and holding the corresponding button (up/down) on a push button switch or turning and holding the switching toggle (left/right) on a rotary switch moves the roller shutter in the selected direction. Releasing the button or turning back the switching toggle stops the roller shutter. When the element has reached the end position during both upward and downward travel, the switching toggle or the push-button must be returned to the starting position to keep the motor voltage-free.

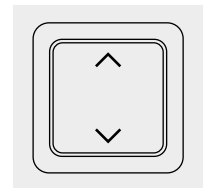
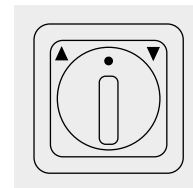

Latching switch

Pressing the corresponding button (up/down) or turning the switching toggle (left/right) moves the roller shutter in the selected direction. By pressing the stop button or the button for the opposite direction (depending on the switch version) or by turning back the switching toggle, the roller shutter stops.

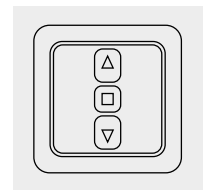

Roller shutter

→ Radio remote control “A”

Operation Remote control “A”

Here you will learn how to operate your roller shutter via the remote control “A”. You can teach up to nine remote controls to one element.

1-channel remote control

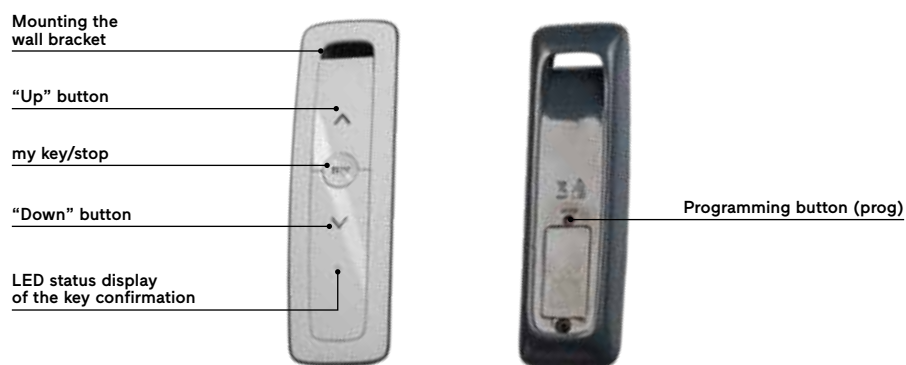

5-channel remote control

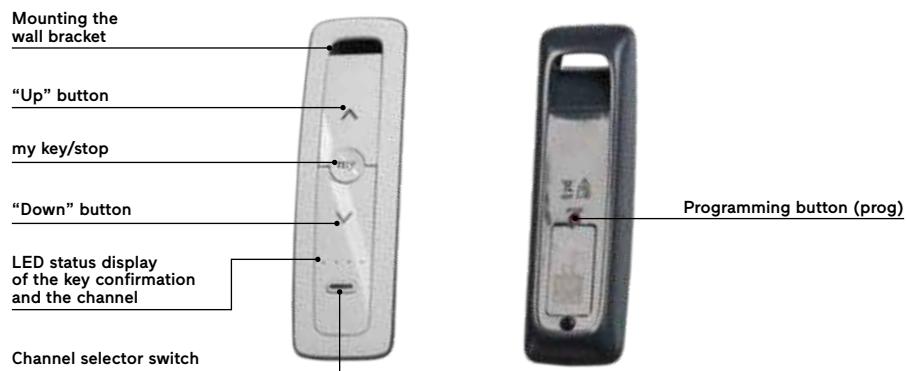

The channels of the 5-channel remote control

There are five different channels. When you press the channel selector switch, you can see which channel you are in. The first four channels are identified by the individual LEDs. The fifth can be identified by the fact that all four LEDs light up. You can change the channel by pressing the channel selector switch again.

LED status display lighting scheme

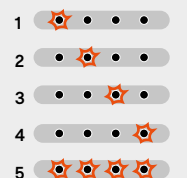

Same channel – multiple elements

You can programme several motorised elements on the same channel. For example, you can store and operate 2 shutters on channel 1 – and 3 other shutters on channel 2.

Reach

The range of the remote controls is up to 40 metres and depends on whether the communication path between the element and the remote control is free or whether there are obstacles (walls etc.) in between. The fewer obstacles there are between the remote control and the element, the further the signal will reach.

Operation

If you have a 5-channel remote control, make sure that the correct channel is selected in which the item(s) to be operated is stored before operating it by pressing the channel selector switch.

The “Up” and “Down” buttons

Briefly pressing the “Up” button raises the roller shutter completely.



By briefly pressing the “Down” button, the roller shutter moves down completely.



The stop function

The roller shutter is in motion. Briefly pressing the “my” key stops the roller shutter. By pressing the “my” key again, the roller shutter continues to move in the direction in which it was moving before stopping.



The favourite position

You can also use the radio remote control to set an intermediate position, a so-called favourite position.

Operating the favourite position

Press the “my” key briefly. The roller shutter moves to the set favourite position.

Preset favourite position

According to the factory setting, the favourite position can, for example, be positioned at half height or at the lower end position. However, a favourite position does not necessarily have to be preset.

Setting/changing the favourite position

Move the shutter to the desired position and stop the shutter. Press the “my” key for as long (approx. 5 seconds) as it takes for the element to move up and down once briefly. The favourite position is now taught.

Roller shutter

→ Radio remote control “A”

Note: with the 5-channel remote control, it is not possible to teach two different favourite positions on two different channels for the same roller shutter. If several channels are set for a roller shutter and a favourite position is taught on one of them, this favourite position is transferred to all other channels set for the roller shutter.

Deleting the favourite position

Press the “my” key. The roller shutter moves to the set favourite position and stops there. Press the “my” key again and keep it pressed (approx. 5 seconds) until the roller shutter moves up and down once briefly. The favourite position is deleted.

Adding a remote control via a taught remote control

If you have a motorised roller shutter that can be operated via a remote control, you can teach in another of the same type via an already taught-in remote control.

1. With a remote control that has already been taught-in, press the programming button (prog) with the help of a thin, pointed object (paper clip, pen, toothpick) for approx. 2 seconds until the roller shutter performs a short up/down movement.
2. If you want to add a 5-channel remote control, first select the desired channel via the channel selector switch. On the remote control that is to be added, press the programming button (prog) using a thin, pointed object (paper clip, pen, toothpick) for approx. 2 seconds until the roller shutter performs a short up/down movement. The remote control is added.

Deleting a remote control via a taught remote control

If you have a motorised roller shutter that can be operated via a remote control, you can delete another one via an already taught-in remote control.

1. With a remote control that has already been taught-in, press the programming button (prog) with the help of a thin, pointed object (paper clip, pen, toothpick) for approx. 2 seconds until the roller shutter performs a short up/down movement.
2. If you want to delete a 5-channel remote control, first select the desired channel via the channel selector switch. On the remote control that is to be deleted, press the programming button (prog) using a thin, pointed object (paper clip, toothpick) for approx. 2 seconds until the roller shutter performs a short up/down movement. The remote control is deleted.

Adding a channel with the 5-channel remote control

1. Make sure the remote control is on the correct channel. To do this, press the channel selector switch, which shows you which channel the remote control is on, and set the correct channel if necessary.
2. Then proceed in the same way as for adding a remote control.

Replacing the battery

If you need to replace the battery, proceed as follows.

1. Unscrew the cover of the remote control as shown in the illustration.



2. Push the empty battery out of the compartment with a plastic object or a screwdriver.



3. Insert a new battery (type CR 2032 3V) into the holder so that the side with the plus sign is visible. Take into account the polarity. The connections must not be short-circuited. Push the battery into the compartment.



4. Refit and screw on the cover.



Wall holder for remote control

The wall bracket is used to attach the remote control to the wall. Here you can find out how to attach it to the wall.

1. Remove the protective film from the adhesive surface on the back of the wall bracket.



2. Attach the wall bracket to a smooth, clean and dry surface. Press it firmly so that it sticks well.



3. Place the remote control on the wall bracket.



Roller shutter

→ Radio remote control “B”

Operation Remote control “B”

In addition to the remote control “A”, the remote control “B” is also available for operating the roller shutters Maxi.

Reach

The range of the remote controls is up to 40 metres and depends on whether the communication path between the element and the remote control is free or whether there are obstacles (walls etc.) in between. The fewer obstacles there are between the remote control and the element, the further the signal will reach.

1-channel remote control

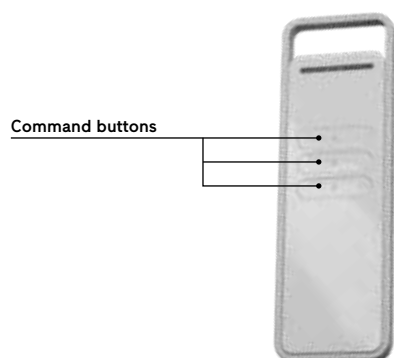

Command buttons

With this remote control, you can operate one or more roller shutters via the command buttons.

Press the ▲ button to raise the roller shutter. Press the ▼ button to lower the roller shutter. Press the

■ button to stop the roller shutter in motion.

6-channel remote control

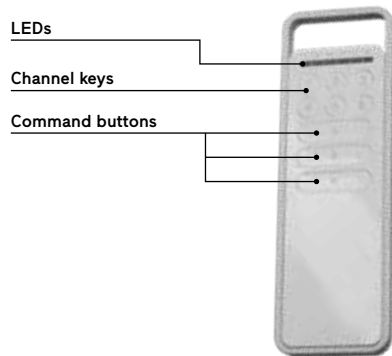

Command buttons

Press the ▲ button to raise the roller shutter. LED of the corresponding channel flashes.

Press the ▼ button to lower the roller shutter. LED of the corresponding channel flashes.

Press the ■ button to stop the roller shutter in motion. LED of the corresponding channel flashes.

Channel keys

The 6-channel remote control has 6 channels that can be operated via the channel keys. Each numbered button represents one channel. One or more roller shutters can be taught and operated in one channel. To select a specific channel, press the corresponding button. The associated LED lights up for several seconds. You can select more channels by pressing additional buttons. After you have selected your desired channels, you can operate the corresponding shutters using the command buttons.

After selecting the desired channels, they remain in the memory when the LEDs are automatically switched off until a new channel (or several new channels) is selected. As long as the selected buttons are in the memory, commands can be directed to them without having to select them again first.

If you have selected an added channel by mistake, you can remove it from the selection by pressing the corresponding button again.

Roller shutter

→ Radio remote control “B”

Teaching a second remote control using the command buttons

Proceed as follows to teach in a new remote control “B” using a functioning remote control that has already been taught in. This procedure is simple and quick.

1. Position the roller shutter at half height.



2. If you have a 6-channel remote control, first select the channel you want to use to operate the roller shutter(s). On the new remote control, press and hold the ■ button for 8 seconds and then release it. The motor does not perform any movement.

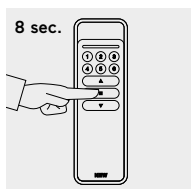

3. Within 60 seconds, press the ■ button 3 times in succession on the remote control that has already been taught in.

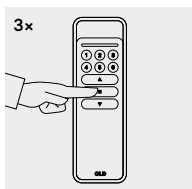

4. Press the ■ button on the new remote control 1 time within 60 seconds to end the procedure. The motor performs 3 movements.

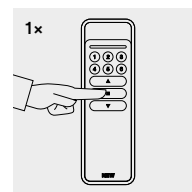

5. When the motor performs 6 movements, the memory is full. During the teach-in process, it is possible to end the teach-in process at any time by pressing and holding ■ and ▼ keys simultaneously for four seconds. Alternatively, you can wait 60 seconds for the motor to perform 6 movements.

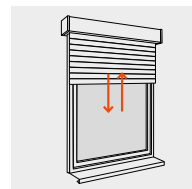

Replacing the batteries

When the batteries become weak, the transmitter significantly reduces its range. In addition, LED turns on later or lights up more dimly when you press a button on the remote control. Replace the batteries as follows.

1. Remove the cover of the remote control.



2. Replace the used batteries with new ones (type AAA). Make sure that the polarity is correct.



3. Replace the cover.



Cleaning

As an externally mounted sunshade, the roller shutters can become dirty over time.

Clean the roller shutters only on the non-hazardously accessible surfaces with a clean, damp cloth and soapy water. Then wipe with another clean, damp cloth and clean water. You will achieve an even better result if you dry the surfaces with a soft cloth.

Do not press too hard on the slats, otherwise they could bend. Do not use a high-pressure cleaner. There is a risk of the surface of the slats being damaged by pressure and heat. Cleaning should be done at least twice a year.

Roller shutter

→ Identifying and solving problems

Roller shutters: identifying and eliminating specific problems

Here you will find problems, their causes and solutions for roller shutters.

Problem	Possible causes	Solutions
The roller shutter does not respond.	The wiring is faulty.	Contact the technical service of the installation company.
	The freeze protection of the drive has been triggered.	Wait until the temperature allows the roller shutter to operate.
	The overheating protection of the drive has been triggered. The overheating protection takes several parameters into account and can be triggered to protect the drive even if the temperature of the shaft is not increased.	Wait a few minutes.
	The battery of the remote control is low.	Replace the battery (see page 47/51).
	The remote control is not compatible with.	Contact the technical service of the installation company.
	The remote control used has not been taught in the drive.	Use a learned remote control or learn this remote control.

Problem	Possible causes	Solutions
The direction of rotation of the drive is not set automatically.	It is a small roller shutter of approx. 0.6m × 0.7m (approx. 0.5m ²).	Bring the roller shutter to the lower position and then raise it again for 5 seconds while braking it with your hand (without stopping it). Then move it back to the lower position. With the next movement, the roller shutter uses the correct direction of rotation.
The roller shutter (Mini roller shutter box with wall button) does not work.	The overheating protection of the drive has been triggered.	Wait until the drive has cooled down.
The roller shutter (Maxi roller shutter box with wall button) does not work.	The thermal protection has been activated.	Wait until the drive has cooled down.
	A technical problem is the cause.	Contact the technical service of the installation company.
The roller shutter (Maxi roller shutter box with wall button) does not respond to the “Up” button. The roller shutter is completely or partially closed.		The roller shutter must be lowered briefly and then raised again.
The roller shutter stops for no apparent reason or without a visible obstacle.	The sensitivity level of the obstacle detection is too high.	Contact the technical service of the installation company.

Roller shutter

→ Identifying and solving problems

Radio remote control “B”: identifying and eliminating specific problems

Here you will find problems, their causes and solutions for the radio remote control “B”.

Problem	Cause	Solution
LED on the remote control flashes 10 times.	When teaching another remote control, there is a communication error between the devices.	Try to teach the remote control again. If the problem persists despite repeated teach-in attempts, contact the technical service of the installation company.
	The maximum time limit was exceeded. The teach-in has not taken place.	Try to teach the remote control again without exceeding the maximum time limit.
A new remote control could not be taught via the already taught remote control. The roller shutter has performed 6 movements.	The time limit of 60 seconds between individual steps of the learning process was exceeded.	Repeat the process and respect the time limit between each step of the learning process.
A new remote control could not be taught via the already taught remote control.	The old remote control is broken.	It is not possible to teach a new remote control with an already taught broken remote control. Contact the technical service of the installation company.

→ Further information

Obstacle detection

Automatic obstacle detection protects the roller shutter curtain from damage and allows obstacles to be removed.

If the roller shutter curtain encounters an obstacle during the downward movement, the blinds stop automatically. Press the “Up” button to unlock the roller shutter.

If the roller shutter curtain encounters an obstacle during the upward movement, the blinds stop automatically. Press the “Down” button to unlock the roller shutter.

The roller shutter can quickly fold down after removing the obstacle and possibly trap body parts and injure you or others. Make sure that there are no objects, body parts, children or adults in the travel area.

Freeze protection

The freeze protection works like the obstacle detection. If the drive detects resistance, it will not start moving to avoid damaging the shutter curtain. The roller shutter remains in its original position.

External Venetian blinds

→ Safety instructions

- Only use the external Venetian blinds for their intended use.
- External Venetian blinds serve as privacy and sun protection in front of a window or door. They do not offer wind or weather protection.
- External Venetian blinds are not suitable as a safety device. Closed external Venetian blinds do not protect against falling out of the window or door.
- There is a risk of falling when opening, closing, cleaning and maintaining the external Venetian blinds. Do not lean out of the window.
- No additional loads may act on the external Venetian blinds.
- Due to its stable construction, the external Venetian blinds are a heavy element. There is a risk of injury in the event of careless operation.
- Close your windows in strong winds. Make sure that there is no draught even in your absence. Closed external Venetian blinds do not withstand every wind load. Note that the specified wind load is only guaranteed when the window is closed. In stronger winds, the external Venetian blinds slats may rattle, but this is not a defect. If wind with a speed of approx. 50km/h is imminent, retract the external Venetian blinds to avoid possible damage.
- The external Venetian blinds can freeze in frosty conditions. Do not operate the external Venetian blinds by force. Do not open or close the external Venetian blinds if they are frozen. After defrosting, operation is possible again. Do not operate the external Venetian blinds if there is snow or ice in the guide rails. In the case of motor-operated external Venetian blinds with automatic switching, switch off the automatic system if there is a risk of freezing.
- Do not push up or pull down the external Venetian blinds by hand. Never push up the external Venetian blinds without operating the drive. This could cause malfunctions.
- There is a risk of injury when closing or opening the external Venetian blinds. Do not reach into the running area of the external Venetian blinds and into the external Venetian blinds rails.
- Take safety measures against crushing hazards, especially when operating the unit with automatic devices.
- The lowering of the external Venetian blinds must not be obstructed. When operating the element, make sure that there are no obstacles, people or animals in the running area and that free running is ensured for the external Venetian blinds rails. Do not reach into or onto moving parts during operation, otherwise there is a risk of injury.
- Place the operating switch within sight of the unit, but not in the area of the moving parts of the unit.
- Do not allow children or animals to play with the controls, such as remote controls or switches of the external Venetian blinds. Keep remote controls away from children and animals.
- We recommend an emergency power supply especially in areas with frequent mains failures. In this way, you can prevent the external Venetian blinds from malfunctioning due to a power failure.
- With automatic gear shift: if external Venetian blinds connected to an automatic system are installed in front of the only access to your balcony or terrace, you can lock yourself out. To avoid this, switch off the automatic system when you are on the balcony or terrace.

→ Wall switch

The motor switches off automatically in the upper and lower end positions. Different variants of switches are available.

Rotary or push-button

Pressing and holding the corresponding button (up/down) on a push button switch or turning and holding the switching toggle (left/right) on a rotary switch moves the external Venetian blinds in the selected direction. Releasing the button or turning back the switching knob stops the external Venetian blinds. When the element has reached the end position during both upward and downward travel, the switching toggle or the push-button must be returned to the starting position to keep the motor voltage-free.

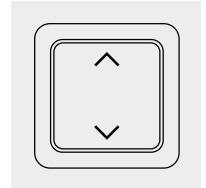
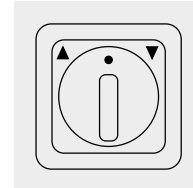

Latching switch

Pressing the corresponding button (up/down) or turning the switching knob (left/right) moves the external Venetian blinds in the selected direction. Pressing the stop button or the button for the opposite direction (depending on the switch version) or turning back the switching toggle stops the external Venetian blinds.

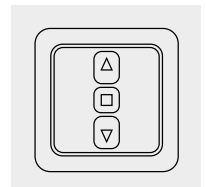

→ Radio remote control

Remote control

You have either a 1-channel or a 5-channel remote control.

1-channel remote control

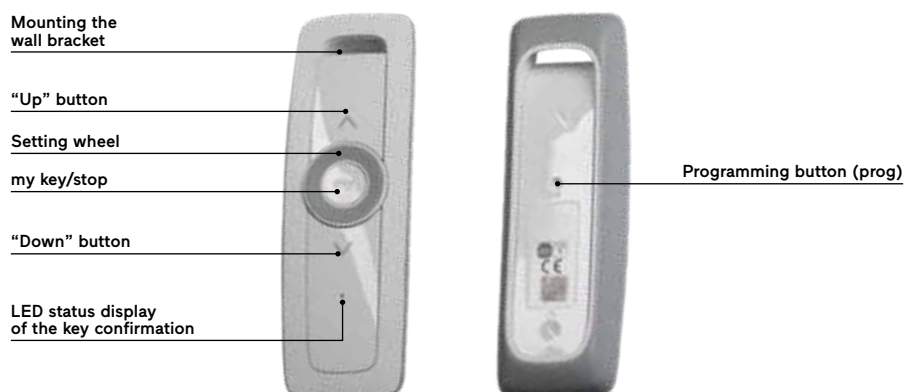

External Venetian blinds

→ Radio remote control

5-channel remote control

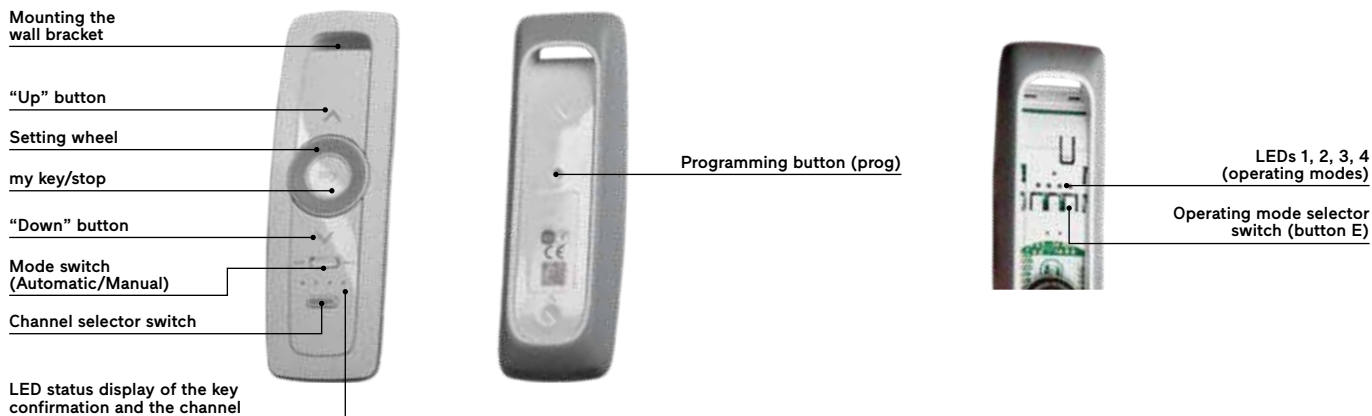

The channels of the 5-channel remote control

There are five different channels. When you press the channel selector switch, you can see which channel you are in. The first four channels are identified by the individual LEDs. The fifth can be identified by the fact that all four LEDs light up. You can change the channel by pressing the channel selector switch again.

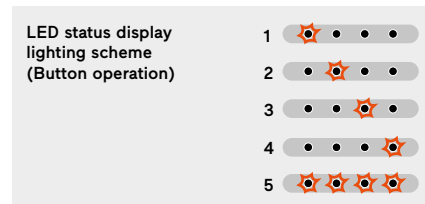

Same channel – multiple elements

You can programme several motorised elements on the same channel. For example, you can store and operate 2 external Venetian blinds on channel 1 – and 3 other external Venetian blinds on channel 2.

Reach

The range of the remote controls is up to 40 metres and depends on whether the communication path between the element and the remote control is free or whether there are obstacles (walls etc.) in between. The fewer obstacles there are between the remote control and the element, the further the signal will reach.

Operation

If you have a 5-channel remote control, make sure that the correct channel is selected in which the item(s) to be operated is stored before operating it by pressing the channel selector switch.

The “Up” and “Down” buttons

By briefly pressing the “Up” button, the external Venetian blinds move completely upwards.



By briefly pressing the “Down” button, the external Venetian blinds move completely downwards.



The stop function

The external Venetian blinds are in motion. Briefly pressing the “my” key stops the external Venetian blinds. By pressing the “my” key again, the external Venetian blinds continue to move in the direction in which they were moving before stopping.

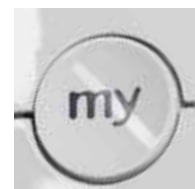

The favourite position

You can also use the radio remote control to set an intermediate position, a so-called favourite position.

Operating the favourite position

Press the “my” key briefly. The external Venetian blinds move to the set favourite position.

Preset favourite position

According to the factory setting, the favourite position can, for example, be positioned at half height or at the lower end position. However, there does not necessarily have to be a preset favourite position.

Changing/setting the favourite position

Move the external Venetian blinds to the desired position and stop the external Venetian blinds. Press the “my” key for as long (approx. 5 seconds) as it takes for the element to move up and down once briefly. The favourite position is now taught.

Note: with the 5-channel remote control, it is not possible to teach two different favourite positions on two different channels for the same external Venetian blinds. If several channels are set for an element and a favourite position is taught on one of them, this favourite position is transferred to all other channels set for the element.

Deleting the favourite position

Press the “my” key. The external Venetian blinds move to the set favourite position and stop there. Press the “my” key again and keep it pressed (approx. 5 seconds) until the external Venetian blinds move up and down once briefly. The favourite position is deleted.

External Venetian blinds

→ Radio remote control

The operating modes

The 5-channel remote control has 4 pre-programmed operating modes. This allows the correct operating mode to be selected depending on the application type of the groups that are to be controlled. For the operation of external Venetian blinds, only operating mode 3 is relevant, to which all channels are already set by default.

Here you can see an overview of the operating modes:

Operating mode 1	Control of all io-homecontrol applications, for example roller shutters. The setting wheel is not active.
Operating mode 2	The setting wheel is active and allows you to control the lighting and heating.
Operating mode 3	The setting wheel is active and allows you to set an adjustable sunshade or a roller shutter with tiltable slats.
Operating mode 4	The setting wheel is active and allows you to move the adjustable slats of indoor blinds.

The operating modes are indicated by individual LEDs.



Changing the operating mode

1. First select the correct channel using the channel selector switch.
2. Remove the back of the remote control.
3. Press the mode selector switch (button E). The operating mode associated with the channel is displayed. Press repeatedly to change the operating mode.
4. Replace the back of the remote control.

Mode switch (Automatic/Manual)

To change the mode, move the mode switch (Automatic/Manual).

Automatic mode: the channel applications respond to all control units and transmitters to which they are connected (specific and general remote controls, timers).

Manual mode: blocks all commands by automatic devices (central home automation of the TaHoma type, timers, sun automation or sensors) to which the applications of the groups are connected.

Setting wheel

You can adjust the inclination of the slats on the external Venetian blinds with the adjustment wheel.

Adjustment by one notch: adjustment of the slats by one step.

Adjustment by several notches: adjustment of the slats by the corresponding number of steps. Quick adjustment: complete inclination of the slats.

Copying the settings to another channel

The settings made in operating modes 3 and 4 can be copied for all channels that use operating modes 3 and 4.

The following settings are copied:

- direction of rotation of the slats
- changing the speed of adjustment of the slats

1. First select the correct channel on the 5-channel remote control.
2. Remove the back of the remote control.
3. Press the operating mode selector switch (button E) until LED flashes (>5 seconds). When the mode selector switch (button E) is released, LED lights up continuously.
4. Press the mode selector switch (button E) again until LED stops flashing (>5 seconds).
5. Reattach the back.

External Venetian blinds

→ Radio remote control

Adding a remote control via a taught remote control

If you have motor-operated external Venetian blinds that can be operated via a remote control, you can teach-in another of the same type via an already taught-in remote control.

1. With a remote control that has already been taught-in, press the programming button (prog) for approx. 2 seconds until the external Venetian blinds perform a short up/down movement.
2. If you want to add a 5-channel remote control, first select the desired channel via the channel selector switch. Press the programming button (prog) on the remote control to be added for approx. 2 seconds until the external Venetian blinds perform a short up/down movement. The remote control is added.

Deleting a remote control via a taught remote control

If you have motorised external Venetian blinds that can be operated via a remote control, you can delete another remote control via one that has already been taught-in.

1. With a remote control that has already been taught-in, press the programming button (prog) for approx. 2 seconds until the external Venetian blinds perform a short up/down movement.
2. If you want to delete a 5-channel remote control, first select the desired channel via the channel selector switch. Press the programming button (prog) on the remote control to be deleted for approx. 2 seconds until the external Venetian blinds perform a short up/down movement. The remote control is deleted.

Adding a channel with the 5-channel remote control

1. Make sure the remote control is on the correct channel. To do this, press the channel selector switch, which shows you which channel the remote control is on, and set the correct channel if necessary.
2. Then proceed in the same way as for adding a remote control.

Information

It is not possible to delete only one channel on a 5-channel remote control. Only the entire remote control can be deleted.

Replacing the battery

If you need to replace the battery, proceed as follows.

1. Remove the cover of the remote control as shown in the illustration. Push the surface upwards with both thumbs placed at the marked points. While doing so, apply light pressure with the thumb that is placed at the upper mark. The remote control can be folded open like this.



2. Push the empty battery out of the compartment with a plastic object or a screwdriver.



3. Insert a new battery (type CR 2430 3V) into the holder so that the side with the plus sign is visible. The connections must not be short-circuited. Push the battery into the compartment.



4. Replace the cover. Make sure to insert the upper part of the remote control first and then press the lower part closed.



Wall holder for remote control

Here you can find out how to attach the wall bracket to the wall.

1. Remove the protective film from the adhesive surface on the back of the wall bracket.



2. Attach the wall bracket to a smooth, clean and dry surface. Press it firmly so that it sticks well.



3. Place the remote control on the wall bracket.



External Venetian blinds

→ Cleaning

As externally mounted sun protection, the external Venetian blinds can become dirty over time.

Clean the slats of the external Venetian blinds with a clean, damp cloth and soapy water. Then wipe with another clean, damp cloth and clean water. You will achieve an even better result if you dry the surfaces with a soft cloth. Do not press too hard on the slats, otherwise you could bend them and the textile straps. Do not use a high-pressure cleaner. There is a risk of the surface of the slats being damaged by pressure and heat.

→ Identifying and solving problems

Problem	Possible causes	Solutions
The external Venetian blinds do not respond.	The wiring is faulty.	Contact the technical service of the installation company.
	The freeze protection of the drive has been triggered.	Wait until the temperature allows the external Venetian blinds to operate.
	The overheating protection of the drive is active.	Wait a few minutes until the drive has cooled down.
	The battery of the remote control is low.	Replace the battery (see page 63).
	The remote control is not compatible with.	Contact the technical service of the installation company.
	The remote control used has not been taught in the drive.	Use a learned remote control or learn this remote control.
The “my” position does not work.	The “my” position is deleted.	Set the “my” position.

Problem	Possible causes	Solutions
The external Venetian blinds stop too early or too late.	The end positions are set incorrectly.	Contact the technical service of the installation company.
The slats are difficult to tilt.	The remote control is not compatible with.	
The slats cannot be properly aligned.	The slat turn or the maximum turn range is not set correctly.	
The “my” position cannot be repeated.	The slat turn is not set correctly.	
The external Venetian blinds run slanted.	The lifting belt runs at an angle.	
The external Venetian blinds are stopped too early.	The end positions have been set incorrectly.	
The position cannot be repeated.	The maximum turning range is not set correctly.	

→ Further information

Obstacle detection during upward movement

If the external Venetian blinds encounter an obstacle during its upward movement, the drive stops immediately and performs a downward movement so that no pressure is exerted on the components of the element. Obstacle detection is activated by default. Obstacle detection is not active during the downward movement of the external Venetian blinds.

Frost detection during upward movement

If the external Venetian blinds are blocked due to frost when starting an upward movement, the drive stops immediately and switches to the downward movement to relieve the element. Frost detection is activated by default.

Independent readjustment of the upper end position

To reduce maintenance, the drive automatically adjusts its upper end position at regular intervals. This function is activated by default.

Overheating protection

The overheating protection protects the drive against overheating. This switches off the drive for a few minutes if it overheats during prolonged operation.

Venetian blinds and pleated blinds

→ Component description

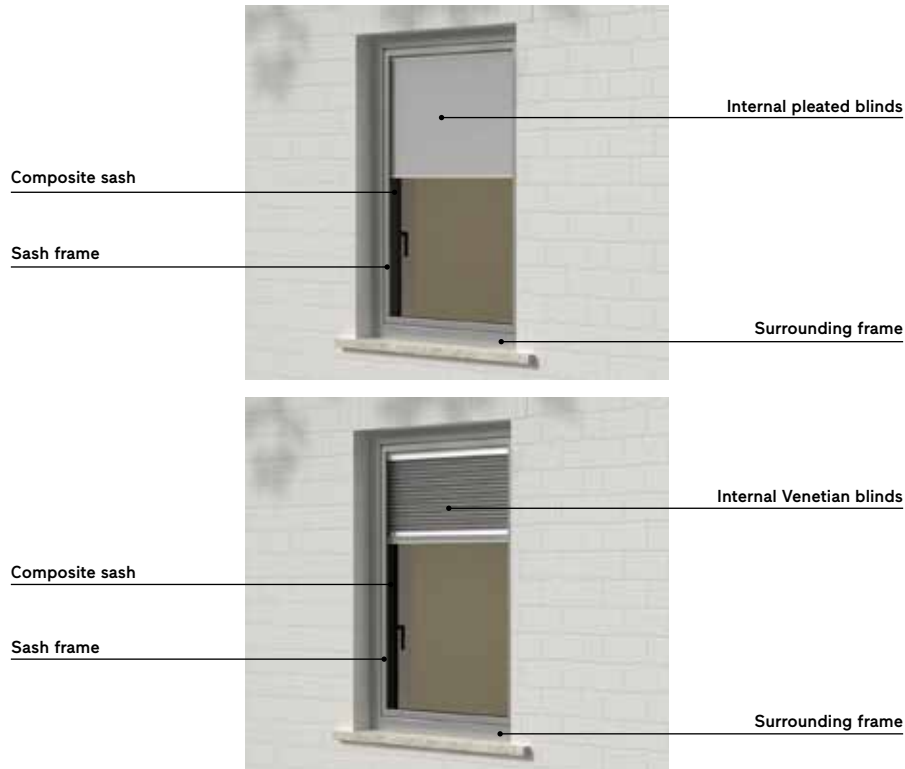

→ Safety instructions

- Only use the Venetian blinds or pleated blinds for the specified purpose.
- Make sure that no obstacles block the running area of the Venetian blinds/pleated blinds.
- Do not reach between the moving parts when the element is in motion. Even when stopped, there is a risk of injury if you reach between the moving parts.
- Do not push up or pull down the slats by hand. Only use the operating options provided for this purpose.
- The Venetian blinds or pleated blinds must not be subjected to any additional loads.
- Important note for chain-operated Venetian blinds and pleated blinds: children, especially small children, can get caught in the loops of the chain drive and strangle themselves. There is a risk that they will wrap the chain around their neck. Keep the chain out of the reach of children. Beds and furnishings should not be near the chains.
- We recommend an emergency power supply especially in areas with frequent mains failures. In this way, you can prevent the Venetian blinds or pleated blinds from malfunctioning due to a power failure.
- Important note for motor-operated Venetian blinds and pleated blinds: do not allow children or animals to play with the operating elements, e.g. radio hand-held transmitter or switch of the Venetian blinds or pleated blinds. Keep radio transmitters away from children and animals.

→ Chain drive

- Pulling the chain raises or lowers the Venetian blinds/pleated blinds. The Venetian blinds/pleated blinds can be stopped in any position. Always pull the chain slowly.
- Check regularly that the chain is properly guided in the upper and lower brackets. Replace the operating device if it is defective.
- If the Venetian blinds/pleated blinds are completely raised and you feel resistance on the chain pull, switch to the other side of the chain for operation in the downward direction. Avoid pulling the chain again in the upward direction to prevent damage to the drive unit.
- The chain bracing must be fixed at least 1.5m above the ground (protection against danger of strangulation/child protection).

→ Wall switch

The motor switches off automatically in the upper and lower end positions. Different variants of switches are available.

Rotary or push-button

Pressing and holding the corresponding button (up/down) on a push button switch or turning and holding the switching toggle (left/right) on a rotary switch moves the Venetian blinds/pleated blinds in the selected direction. Releasing the button or turning back the switching toggle stops the element. When the element has reached the end position during both upward and downward travel, the switching toggle or the push-button must be returned to the starting position to keep the motor voltage-free.

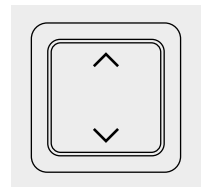
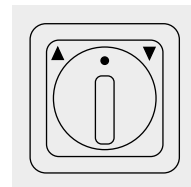

Latching switch

Pressing the corresponding button (up/down) or turning the switching knob (left/right) moves the Venetian blinds or pleated blinds in the selected direction. By pressing the stop button or the button for the opposite direction (depending on the switch version) or by turning back the switching toggle, the element stops.

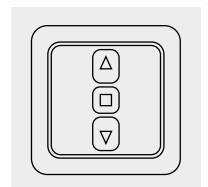

Venetian blinds and pleated blinds

→ Radio remote control

Remote control

You have either a 1-channel or a 5-channel remote control.

1-channel remote control

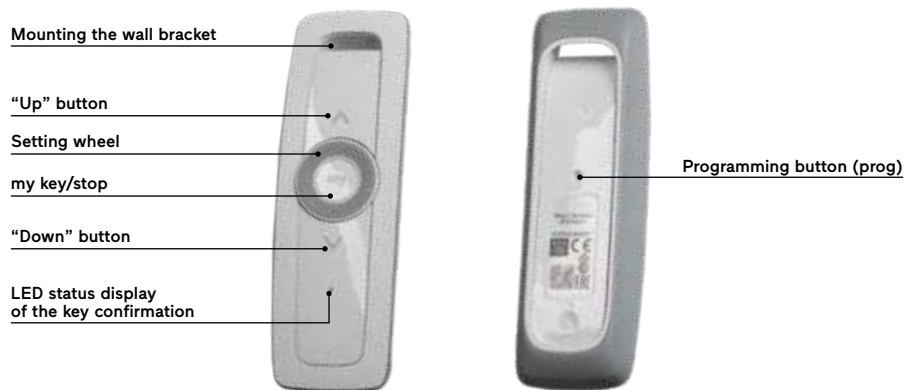

5-channel remote control

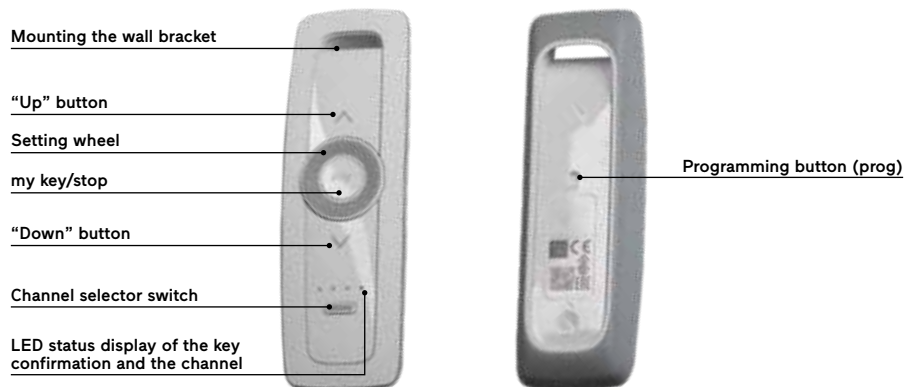

The channels of the 5-channel remote control

There are five different channels. When you press the channel selector switch, you can see which channel you are in. The first four channels are identified by the individual LEDs. The fifth can be identified by the fact that all four LEDs light up. You can change the channel by pressing the channel selector switch again.

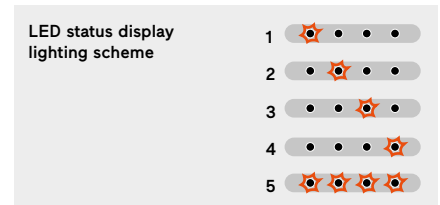

Same channel – multiple elements

You can programme several motorised elements on the same channel. For example, you can store and operate 2 Venetian blinds or pleated blinds on channel 1 and 3 other blinds or pleated blinds on channel 2.

Reach

The range of the remote controls is up to 40 metres and depends on whether the communication path between the element and the remote control is free or whether there are obstacles (walls etc.) in between. The fewer obstacles there are between the remote control and the element, the further the signal will reach.

Operation

If you have a 5-channel remote control, make sure that the correct channel is selected in which the item(s) to be operated is stored before operating it by pressing the channel selector switch.

The “Up” and “Down” buttons

By briefly pressing the “Up” button, the Venetian blinds or pleated blinds move completely upwards.



By briefly pressing the “Down” button, the Venetian blinds or pleated blinds move completely downwards.



The stop function

The Venetian blinds or pleated blinds are in motion. Pressing the “my” key briefly stops the element. By pressing the “my” key again, the element continues to move in the direction it was moving before it stopped.



Venetian blinds and pleated blinds

→ Radio remote control

Setting wheel

With the adjusting wheel you can adjust the inclination of the slats on the Venetian blinds.

Adjustment by one notch: adjustment of the slats by one step.

Adjustment by several notches: adjustment of the slats by the corresponding number of steps. Quick adjustment: complete inclination of the slats.

The favourite position

You can also use the radio remote control to set an intermediate position, a so-called favourite position.

Operating the favourite position

Press the “my” key briefly. The Venetian blinds or pleated blinds move to the set favourite position.

The preset favourite position

After factory setting of the raising and lowering times, the favourite position is the lower end position, for Venetian blinds with a slat angle of 45°.

Changing the favourite position

1. To change the favourite position, the Venetian blinds or pleated blinds must be in the upper end position.
2. Press the “my” key for about 5 seconds until the element starts a movement. The Venetian blinds or pleated blinds move to the favourite position already saved. If the favourite position was deleted beforehand, it will move to the favourite position preset at the factory for the first time.
3. Readjust the favourite position using the “Up” and “Down” buttons (and the scroll wheel in case of Venetian blinds).
4. Press the “my” key for about 5 seconds until the element confirms with a short up/down movement. The new favourite position is saved. With Venetian blinds, the slats are always closed.

Note: if the favourite position has been newly set, the element first moves completely to the lower end position when the “my” key is pressed, stops for a few seconds and then moves to the set favourite position.

Deleting the favourite position

Press the “my” key. The Venetian blinds or pleated blinds move to the set favourite position and stays there. Press the “my” key again and keep it pressed (approx. 5 seconds) until the element moves up and down once briefly. The favourite position is deleted. To relearn a favourite position, see “Changing the favourite position” (page 70).

Adding a remote control via a taught remote control

If you have a motorised Venetian blinds or a motorised pleated blinds that can be operated via a remote control, you can use an already taught-in remote control to teach in another of the same type.

1. With a remote control already taught-in, press the programming button (prog) for approx. 2 seconds until the element performs a short up/down movement.
2. If you want to add a 5-channel remote control, first select the desired channel via the channel selector switch. Press the programming button (prog) on the remote control to be added for approx. 2 seconds until the element performs a short up/down movement. The remote control is added.

Deleting a remote control via a taught remote control

If you have a motor-operated Venetian blinds or a motor-operated pleated blinds that can be operated via a remote control, you can delete another one via an already taught-in remote control.

1. With a remote control already taught-in, press the programming button (prog) for approx. 2 seconds until the element performs a short up/down movement.
2. If you want to delete a 5-channel remote control, first select the desired channel via the channel selector switch. Press and hold the programming button (prog) on the remote control to be deleted for approx. 2 seconds until the element makes a short up/down movement. The remote control is deleted.

Adding a channel with the 5-channel remote control

1. Make sure the remote control is on the correct channel. To do this, press the channel selector switch, which shows you which channel the remote control is on, and set the correct channel if necessary.
2. Then proceed in the same way as for adding a remote control.

Venetian blinds and pleated blinds

→ Radio remote control

Replacing the battery

If you need to replace the battery, proceed as follows.

1. Remove the cover of the remote control as shown in the illustration. Push the surface upwards with both thumbs placed at the marked points. While doing so, apply light pressure with the thumb that is placed at the upper mark. The remote control can be folded open like this.



2. Push the empty battery out of the compartment with a plastic object or a screwdriver.



3. Insert a new battery (type CR 2430 3V) into the holder so that the side with the plus sign is visible. The connections must not be short-circuited. Push the battery into the compartment.



4. Replace the cover. Make sure to insert the upper part of the remote control first and then press the lower part closed.



Wall holder for remote control

The wall bracket is used to attach the remote control to the wall. Here you can find out how to attach it to the wall.

1. Remove the protective film from the adhesive surface on the back of the wall bracket.



2. Attach the wall bracket to a smooth, clean and dry surface. Press it firmly so that it sticks well.



3. Place the remote control on the wall bracket.



→ Cleaning

Twin composite sash

Cleaning the glass surfaces in the space between the panes or the Venetian blinds/pleated blinds

1. To clean, first open the locks between the sashes and carefully push them apart. To do this, flip open the bolts.

Bolt on

first opening sash for composite sash Slim-line Twin/Slim-line Cristal Twin or Nova-line Twin/Nova-line Cristal Twin



second opening sash in a double-sash window with composite sash Nova-line Twin/Nova-line Cristal Twin



2. Clean the inner glasses following the cleaning instructions (see chapter "Cleaning and maintenance", page 82–86). If you want to clean the Venetian blinds or pleated blinds, move the Venetian blinds or pleated blinds downwards, but not to the end stop.



3. Press all components together again correctly and close the locks completely. Be careful not to pinch the Venetian blinds or pleated blinds.

Venetian blinds and pleated blinds

→ Cleaning

Note

Venetian blinds and pleated blinds are sensitive components. Clean them carefully and gently. When cleaning, also take care not to damage or scratch the glass of the window.

Cleaning pleated blinds

Use a dry, antistatic cloth and wipe the surface gently from one side to the other.

Cleaning Venetian blinds

Use a dry, antistatic cloth and carefully wipe the slats one by one from one side to the other. When cleaning Venetian blinds, pay particular attention to the edges of the slats. They can cause injuries to the skin.

Cleaning the inner surface of the glass

If you want to clean the inner surfaces of the glass, raise the Venetian blinds or pleated blinds completely before doing so in order not to damage the element during cleaning.

→ Identifying and solving problems

Problem	Possible causes	Solutions
The Venetian blinds or pleated blinds do not respond to the command via the remote control.	The wiring is faulty.	Contact the technical service of the installation company.
	The battery of the remote control is low.	Replace the battery (see page 72).
	The remote control is not compatible with.	Contact the technical service of the installation company.
	The remote control used has not been taught in the drive.	Use a learned remote control or learn this remote control.
	After cleaning, the components were not properly pressed together and closed.	Make sure that all components are correctly closed.
The Venetian blinds or pleated blinds move in the wrong direction: when the “Up” button is pressed, the element moves down and when the “Down” button is pressed, the element moves up.	An error was made during reprogramming (for example, while changing the favourite position).	<ol style="list-style-type: none"> 1. Position the element in the centre. 2. Press the “Up” and “Down” buttons simultaneously until the element performs a short up/down movement. 3. Press the “my” key until the element performs a short up/down movement again. 4. Test the direction by pressing the “Up” and “Down” buttons. If it is still not correct, repeat steps 3 and 4 until the direction is correct. 5. Press the “my” key until the element again performs a short up/down movement. 6. Press the “my” key again until the element again performs a short up/down movement. (= repeat step 5)
A loud humming sound is heard when the Venetian blinds are raised.	The end cap is offset.	Move the Venetian blinds all the way down once and then back up again. If the humming continues, contact the technical personnel of the installation company.

Fabric shades

→ Safety instructions

- Only use the fabric shade for its intended use.
- Fabric shades serve as privacy and sun protection in front of a window or door. They do not offer wind or weather protection.
- Fabric shades are not suitable as a safety device. A closed fabric shade does not protect against falling out of the window or door.
- There is a risk of falling when opening, closing, cleaning and maintaining the fabric shade. Do not lean out of the window.
- No additional loads may act on the fabric shade.
- Due to its construction, the fabric shade is a heavy element. There is a risk of injury in the event of careless operation.
- Close your windows in strong winds. Make sure that there is no draught even in your absence. Closed fabric shades do not withstand every wind load. Note that the specified wind load is only guaranteed when the window is closed. If wind with a speed of approx. 50km/h is imminent, retract the fabric shade to avoid possible damage.
- The fabric shade may freeze in frosty conditions. Do not operate the fabric shade by force. Do not open and close the fabric shade if it is frozen solid. After defrosting, operation is possible again. Do not operate the fabric shade if there is snow or ice in the guide rails. In case of motor-driven fabric shades with automatic switching, switch off the automatic system if there is a risk of freezing.
- Do not push up or pull down the fabric shade by hand. Never push up the fabric shade without operating the drive. This could cause malfunctions.
- There is a risk of injury when closing or opening the fabric shade. Do not reach into the running area of the fabric shade and into the rails.
- Take safety measures against crushing hazards, especially when operating the unit with automatic devices.
- The removal of the fabric shades must not be obstructed. When operating the element, make sure that there are no obstacles, people or animals in the running area and that free running is ensured for the rails of the fabric shade. Do not reach into or onto moving parts during operation, otherwise there is a risk of injury.
- Place the operating switch within sight of the unit, but not in the area of the moving parts of the unit.
- Do not allow children or animals to play with the controls, such as remote controls or switches of fabric shades. Keep remote controls away from children and animals.
- We recommend an emergency power supply especially in areas with frequent mains failures. This will prevent malfunction of the fabric shade due to a power failure.
- With automatic gear shift: if a fabric shade is installed in front of the only access to your balcony or terrace and is connected to an automatic system, you could lock yourself out. To avoid this, switch off the automatic system when you are on the balcony or terrace.

→ Wall switch

The motor switches off automatically in the upper and lower end positions. Different variants of switches are available.

Rotary or push-button

By pressing and holding the corresponding button (up/down) on a push button switch or by turning and holding the switching toggle (left/right) on a rotary switch, the fabric shade moves in the selected direction. Releasing the button or turning back the switching toggle stops the element. When the element has reached the end position during both upward and downward travel, the switching toggle or the push-button must be returned to the starting position to keep the motor voltage-free.

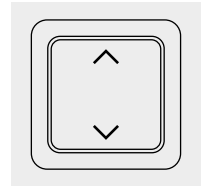
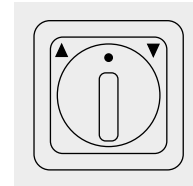

Latching switch

By pressing the corresponding button (up/down) or by turning the switching knob (left/right), the fabric shade moves in the selected direction. By pressing the stop button or the button for the opposite direction (depending on the switch version) or by turning back the switching toggle, the element stops.

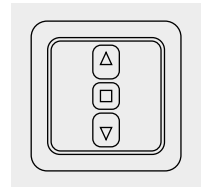

→ Radio remote control

The operation of a fabric shade via a radio remote control corresponds to that of a roller shutter with radio remote control "A". Therefore, refer to the contents on pages 44–47.

→ Cleaning

We recommend cleaning the surface of the fabric and the aluminium rails at least once per year.

Cleaning instructions

- For cleaning, do not use strong alkaline detergents, harsh cleaners, solvents, alcohol, acids (e.g. rust solvents), especially hydrofluoric acid, or cleaning agents or paper wipes containing fluoride. You could etch the surface and cause irreparable damage.
- Do not use abrasive cleaners, abrasive polishes or other cleaners containing ketones or esters. Abrasive cleaning agents or aids and scratching tools such as brushes, steel wool, steel scrapers, scouring pads, floor knives, razor blades or similar can scratch the surface and must also not be used.
- Do not apply silicone spray, oil or grease to the housing, curtain, motor or rails.
- If your fabric shade is accessible from the outside (terrace, balcony), you can also clean it from the outside. Otherwise, the fabric shade may only be cleaned from the inside in order to exclude the risk of falling.

Fabric shades

→ Cleaning

1. Preparation

Clean the fabric shade only when no precipitation or wind is forecast. Lower the fabric shade. Put on cleaning gloves and have two buckets of warm water ready. Put a few squirts of a pH-neutral detergent in one of them. Have a soft, non-metallic brush, a soft sponge and two cloths ready.



2. Clean wipe

Carefully dry clean light soiling with a brush. Then moisten the sponge with the water from the bucket in which the squirts of detergent (pH neutral) were put. Then wipe the surface of the shade with the sponge. Wipe in a circle from the edge of the fabric shade to the centre.



3. Wipe clean

Wash the cloth in the bucket of warm water and then wring out the cloth so that it does not drip. Wipe the surface. Then also wipe the aluminium rail of the fabric shade.



4. Dry wiping

Work on the edges and damp spots with the second, dry cloth.



5. Drying out

Allow the fabric shade to dry out thoroughly before raising it again.

→ Further information

Obstacle detection

Automatic obstacle detection protects the fabric shade from damage and allows obstacles to be removed.

If the fabric shade encounters an obstacle during downward movement, the blinds stop automatically. Press the “Up” button to unlock the fabric shade.

If the fabric shade encounters an obstacle during upward movement, the blinds stop automatically. Press the “Down” button to unlock the fabric shade.

The fabric shade can quickly fold down after the obstacle has been removed, possibly trapping body parts and injuring you or others. Make sure that there are no objects, body parts, children or adults in the travel area.

Freeze protection

The freeze protection works like the obstacle detection. If the drive detects resistance, it will not start moving to avoid damaging the shade. The fabric shade remains in its original position.

Awning fabrics

Fabric shade fabric may possibly have the following characteristics. However, these do not affect the proper use and durability of the product.

Creases

When cutting, sewing or folding the fabrics, stripes may appear due to creasing.

Chalk effect

The impregnating agent applied at the factory may cause light lines in the fabric. Especially with dark fabrics, they cannot be avoided despite careful handling.

Wavy patterns

When rolling up and down on the shaft, the fabric is stretched more in the hem, seam and panel area than between the seams. This could create wavy patterns that become visible when extended. Especially with zip-guided systems, the waves in the edge area are caused by the design and cannot be stopped, as the fabric and the zip lie on top of each other and cover different paths during winding.

Honeycombing

Due to the manufacturing process of the cloth, honeycombing is unavoidable. Rain or increased humidity can intensify this effect. When the cloth is run in wet, these honeycombs become particularly imprinted.

Web error

When making the cloth, threads may break or the thread thickness varies slightly. This creates light dots or pimples in the cloth.

Folding/sliding shutter

→ Component description



→ Safety instructions

- Only use the folding or sliding shutter for its intended use.
- The folding or sliding shutter is a closure that serves as privacy and sun protection in front of a window or door. The folding or sliding shutter is not suitable as a holding or fall protection. A closed folding or sliding shutter does not protect against falling out of the window or door.
- There is a risk of falling when opening, closing, cleaning and maintaining the folding or sliding shutter. Do not lean out of the window.
- In case of draught or strong wind, opened or not locked folding or sliding shutters can open or close suddenly on their own. This can damage folding or sliding shutters. Damage can also be caused to persons, animals or objects that are in the running area.
- Due to the stable construction, the folding or sliding shutter is a heavy element. There is a risk of injury in the event of careless operation.
- No additional loads may act on the folding or sliding shutter.
- Close the folding shutters in gale-force winds, as the open position in the detent holder is not suitable for this. At wind speeds of over 60km/h (storm) and unfavourable positioning of the element, deformation of the fittings and consequential damage can occur.
- If a hinge arrester is fitted, the panel must rest against the wall with the buffer stop in the open position. Corresponding adjustment options are an adjustment device for the hinge arrester or an adjustment of the hinges and cones. Please contact the technical service of the installation company.

→ Operation

- When opening and closing, pay attention to the operating sequence of the folding shutter sashes. Ensure proper locking when closing, and proper unlocking of all locking points before opening. Avoid rough movements and high use of force when opening and closing.
- There is a risk of injury when closing and opening the folding or sliding shutters. Do not reach between the respective attachment points (e.g. between the mounting frame and the folding shutter).

- In the open position, the folding or sliding shutter must be fixed by means of a shutter holder. The folding shutter must not sit loosely in the shutter holder. Otherwise, there is a risk that fastening screws will loosen due to possible vibrations of the folding shutter. Do not insert any objects into the gap between the folding or sliding shutter and the frame.
- The opening and closing of the folding or sliding shutter must not be obstructed. Make sure that no objects obstruct the running area of the folding or sliding shutter.
- In wind speeds of 40km/h and above, folding or sliding shutters must be closed and locked with extreme caution. Close your windows and doors in strong winds. Make sure that there is no draught even in your absence. The specified wind class is only guaranteed when the window or door is closed.
- Should you use folding or sliding shutters without ventilation slots as sun protection, we recommend that you ensure adequate air exchange in the space between the window/door and the folding shutter.
- Closed shutters do not provide complete shading.
- In frosty conditions, folding or sliding shutters and folding shutter fittings can freeze. Do not operate the folding shutter by force. Do not open and close the folding shutter if it is frozen solid. After defrosting, operation is possible again.

→ Cleaning of folding shutters

Cleaning of folding shutters with plastic surface

For cleaning folding shutters with a plastic surface, see the instructions on page 84.

Cleaning of folding shutters with painted plastic surface

Painted shutters in intensive colours may stain slightly when cleaned. This does not represent a reduction in quality and in no way affects the durability of the coating. Painted plastic surfaces of folding shutters require special additional care at least once a year. For this purpose, we recommend our special Finstral care product for coated surfaces.

Cleaning aluminium sliding shutters

As a matter of principle, no acidic or alkaline agents may be used on our aluminium surfaces, which are always powder-coated. The pH value must not be <5 (acidic), or >8.5 (alkaline). Do not use abrasive cleaners, abrasive polishes or any other cleaner containing ketones or esters on matt surfaces, as they will make them shiny. Abrasive cleaning agents or aids such as steel wool etc. can scratch the surface and must also not be used. Agents such as Schleifix are also unsuitable for powder-coated surfaces and leave scouring marks. Special cleaning tips can be found on page 84.

Cleaning and maintenance

→ Proper care

Questions and answers about care

Here you will find some useful answers to questions about the correct care of our products.

How often should I clean and maintain my windows?

In the case of new construction or renovation, you should start cleaning immediately after installation of the products so that remnants of building materials such as concrete, plaster or paint are removed before they can dry on. Clean and maintain your windows, doors and related accessories at least twice a year. This way they last longer and always stay beautiful. Protected areas can pose a greater risk to the coating on window frames with an aluminium surface than unprotected areas. This is because salt and other pollutants from the air settle on the surface and do not come off with the rain. Check the protected areas and clean them more frequently if necessary.

What is the best way to clean?

Thorough cleaning should be done at least twice a year. This way, you prevent deposits caused by dust, smoke or exhaust gases, which can damage materials and components and impair the appearance of the surface. Regular cleaning is especially important near the sea and sources of dust. If the contamination is hard matter (bird droppings etc.), you should remove them immediately.

What is the best way to clean?

Light soiling can be soaked in warm water with a few squirts of a pH-neutral detergent. Then remove the contamination with a microfibre cloth.

What must I not use for cleaning?

For cleaning, never use strong alkaline detergents, harsh cleaners, solvents, alcohol, acids (e.g. rust solvents), especially hydrofluoric acid, or cleaning agents or paper wipes containing fluoride. You could etch the surface and cause irreparable damage. Do not use scouring agents, abrasive polishes or other cleaners containing ketones or esters, especially for matt surfaces, as this will make the surface shiny. Abrasive cleaning agents or aids such as steel wool etc. can scratch the surface and must also not be used. Scratching tools such as brushes, steel wool, steel scrapers, scouring pads, floor knives, razor blades or similar cause scratch marks on the surface and must not be used. Generally, avoid products containing chlorate (e.g. bleach) because they impair the lustre of the surface.

How do I avoid streaking?

Streaks are often caused by cleaning with organic solvents in combination with cold water and repeatedly used wipes. For cleaning without shading or streaks, we recommend wiping with warm water and drying the surface with commercially available microfibre cloths.

What should be considered for the initial cleaning after installation?

First remove the protective film. Then remove the label and keep it. Contamination of the surface by secretions of building materials, mortar and cement slurries leads to cauterisation and thus irreparable damage. Remove the contamination immediately.

How do I clean bottom-hung windows?

Windows with pure tilt fittings must be cleaned from the outside. Opening of the sash is only possible by specialists.

→ Cleaning in individual steps

Step by step to a perfectly cleaned window

Here we describe step by step how best to clean a window.

1. Prepare

Put on cleaning gloves and have two buckets of warm water ready. Put a few squirts of a pH-neutral detergent in one of them. Have two clean microfibre cloths ready.



2. Clean wipe

Wipe the surface of the element with a water-wet, non-dripping microfibre cloth from the bucket in which the splashes of cleaning agent (pH neutral) were placed. This is how you remove sand and dust and soak stubborn dirt. Then rub them away vigorously with a cloth. For glass, use a glass scraper carefully if absolutely necessary (for example, for stickers). Wait until everything has soaked in. Make sure that the scraper is correctly attached. Only work with intact, sharp blades.



3. Cleaning all around

Now open the element. Wash the microfibre cloth in the bucket with the detergent (pH neutral) and then wring it out so that it does not drip. Wipe the inside of the frames and sashes including all fittings with a damp cloth. Use the cleaning sponge with abrasive fleece for stubborn dirt on the frame. Always pre-water sufficiently.



4. Wipe clean

Dip another clean microfibre cloth into the bucket of clean water. Wipe all parts of the element thoroughly. There really should be no cleaning agent left on glass surfaces. This could be "burnt in" by the sun and cause discolouration and streaks.



5. Dry wiping

First pull the edges of the glass dry with the squeegee. Then pull off the remaining wet window field with slalom-like movements. Set down as little as possible but as often as necessary to shake the water off the rubber liner. Work around the edges and wherever it is still damp with a dry microfibre cloth.



Cleaning and maintenance

→ Surface care

Notes for the respective materials

Finstral uses only high-quality materials that are extremely robust and weather-resistant. But of course, long life also depends on proper care. Below, you will learn how to properly clean and care for the surfaces of your elements and what you should pay special attention to.

Notes for plastics

Commercially available special antistatic cleaning agents are not suitable for cleaning plastic. There is a risk of the surface becoming dull or brittle or fading. Do not stick adhesive tape to the surfaces. Over time, dust and sand can get caught underneath and stain the surface.

Notes for aluminium

As a matter of principle, no acidic or alkaline agents may be used on our aluminium surfaces, which are always powder-coated. The pH value must not be <5 (acidic), or >8.5 (alkaline). Do not use abrasive cleaners, abrasive polishes or any other cleaner containing ketones or esters on matt surfaces, as they will make them shiny. Abrasive cleaning agents or aids such as steel wool etc. can scratch the surface and must also not be used. Agents such as Schleiffix are also unsuitable for powder-coated surfaces and leave scouring marks. Clean all surfaces with a soft cloth or sponge, at most with a brush made of soft natural bristles. If air pollution has left visible stains on the coating, you should remove them with stronger cleaners. You should always dilute these and test them in advance on a non-visible area.

Notes for glass

To avoid scratches when using glass scrapers, observe the following: soak the dirt or adhesive to be removed well with water. Make sure the scraper has the correct attachment and only work with intact and sharp blades. Never use strong alkaline detergents, acids, especially hydrofluoric acid, or cleaning agents containing fluoride to clean glazing. These solutions can etch the glass surface and cause irreparable damage. After mounting, it is recommended to remove the labels and residues of the spacer plates within a few days and to dissolve any adhesive residues with a mild cleaning agent. Glass stains that cannot be removed with plenty of clean water, a sponge, a scraper, chamois leather or commercially available spray cleaners and rags can be removed with mild household cleaning agents. Do not carry out any work with cut-off grinders or welding equipment near glazing. The sparks and welding beads damage the glass surface irreparably. We advise against using special glass cleaners. This way you keep the risk of streaking as low as possible.

Notes for wood

In general, make sure that the room humidity does not exceed 60%. If the humidity is above this, ventilate the rooms regularly and several times a day. Clean the wooden surfaces in the direction of the grain with a soft, dry microfibre cloth. The precious wood used for the inlay on carrier boards version can only be cleaned with a damp cloth.

Notes for ceramics

Metallic or scratchy objects (scrapers, steel wool etc.) can leave a stubborn metal abrasion and must not be used.

→ Annual maintenance

Regular control

Finstral windows and doors are high quality and durable and require little maintenance and care. Nevertheless, you should carry out these small checks at least once a year.

Fittings

To maintain the function and ease of movement of the fittings of windows and casement doors, clean the moving parts of fittings once a year with a small brush and grease them with oil. Then open and close the window several times so that the oil can spread. Do not use dissolving or acidic lubricants or oils (e.g. rust-dissolving sprays). Apply lubricants only to the parts of fittings and make sure that they do not get onto the profile surface.

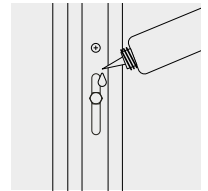

Sash retention device

Regularly observe the wire rope during use for any noticeable defects. Have an obviously defective wire rope replaced immediately by a specialist.

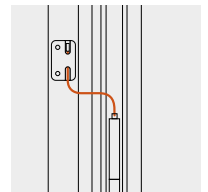

Drainage slots

Open the window and regularly check the drainage slots in the frame. Remove any blockages with a small brush.

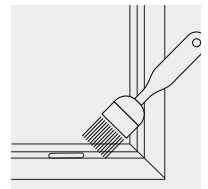

Cleaning and maintenance

→ Annual maintenance

Seals

Clean the seals once a year. They stay elastic longer if you wipe them regularly with a damp cloth. On Nova-line sashes, the outer glass edge seal has a larger area to the weather side and should therefore be cleaned several times a year.

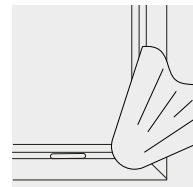

Glass breakage

The all-round bonding of the window sash to the insulating glass is particularly stable and thus guarantees perfect functional reliability in the long term. In the event of glass breakage, replacement must be carried out by qualified personnel in accordance with our instructions in written or video form. For some sash shapes, it makes more economic sense to replace the new glazing including the frame. Ask your Finstral sales consultant for more information.

Further notes

Regularly inspect windows, doors, roller shutters, Venetian blinds or folding shutters and their controls for signs of wear and damage and for stability. We recommend that you have all parts of fittings checked and serviced regularly by a specialist. In case of damage, only original spare parts may be used.

Maintenance that goes beyond the checks listed above, as well as repairs or disassembly, may only be carried out by trained specialist personnel. Damage to fitting parts may only be repaired with original spare parts. Do not carry out any repairs yourself. Do not use the windows, doors, roller shutters, Venetian blinds or folding and sliding shutters if repair is required. Inspection or maintenance of electrical elements must only be carried out by professionals.

Notes for folding shutters

At least once a year, check safety-relevant parts of fittings (cones, hinges, etc.), the retaining brackets and the fastening screws of folding shutters for wear, damage, tight fit or breakage, both when closed and when open. Clean the movable parts of fittings once a year with a small brush.

Tighten the screw (see illustration) hand-tight (4–6Nm). Do not use a cordless screwdriver.

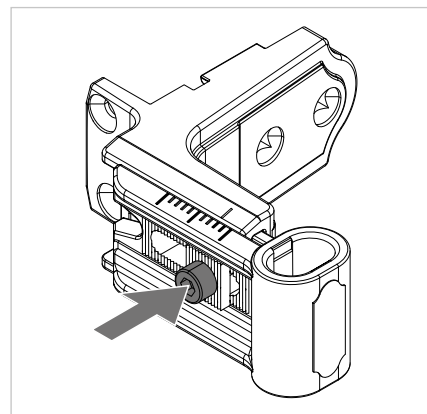

Cleaning the travel rails

Clean the travel rails of the sliding elements regularly with a vacuum cleaner.

Troubleshooting

→ Frequently asked questions

Why did external condensation not previously occur with insulating glass?

Because thermal insulation was worse with these old insulating glass panes or single glazing. Significantly more heat was lost from the heated interior, which meant that the exterior windows were automatically heated as well – at the expense of overall energy consumption, of course. And because the poorly insulated outer windows were warmer, they did not fog up, or only rarely.

Why does the inner surface of the outer pane of the composite sash fog up?

On cold nights, the inner surface of the outer pane cools not only due to the ventilation of the space between the panes, but also via radiation to the outside. If the humidity of the outside air is high in autumn and spring, condensation will then form on the inside surface of the outer pane. With composite sashes, this physical regularity cannot be avoided and is not a defect. As soon as the outside temperature rises, the windows dry again.

Why do windows fog up on the outside?

Insulating glass with a high thermal insulation value ensures that as little heat energy as possible is transported from the inside to the outside (the lower the U_g value, the lower the energy loss). The result: the temperature of the outer pane is approximately the same as the outside air. If you open the window, warm and humid room air comes into contact with the cold outer glass pane and condenses. If the humidity of the outside air is high, condensation forms on the outside pane even when the windows are closed. Fogged outer panes are therefore not a defect, but a sign of the excellent thermal insulation of modern heat insulation insulating glass. As soon as the outside temperature rises, the windows dry again.

How does condensation occur on interior windows?

Condensation on inner panes is much rarer with modern thermal insulation glass than with older insulating glass. Due to the improved thermal insulation, the surface temperature deviates only slightly from the room temperature. If the room air is very humid, for example when cooking or in the bathroom, the interior windows can still mist up. Regular ventilation prevents the excess humidity from condensing on the walls and condensation from becoming visible on the glass surface. At the edge of the glass, the surface temperature is lower than in the centre of the glass due to the glass spacer. That is why the glass always fogs up at the edge first. In buildings with room ventilation systems, please ensure that the controlled humidity is set to a maximum of 50%.

Troubleshooting

→ Frequently asked questions

Why do suction cup or label marks become visible on the pane surface?

Suction or label marks may become visible on glass surfaces due to dew, rain or cleaning water. As soon as the pane is dry, the marks disappear. The reason for these imprint marks is the physical phenomenon of the different wettability of surfaces. That's how it occurs: during the production of insulating glass, the individual panes are cleaned in a special washing plant. In the process, the glass surfaces are extraordinarily clean and chemically-physically activated. If these cleaned glass surfaces come into contact with foreign materials (vacuum cups, grease, label adhesive, etc.), they absorb parts of them. This is unavoidable and does not represent a defect, because the panes are absolutely clean in normal humidity. Over time, this varying wettability will largely dissipate through regular cleaning of the panes.

Why can insulating glass have colour variations?

Glasses have a colour of their own. This inherent colour can – depending on the viewing angle – be identifiable differently in the see-through and/or in the view. Fluctuations in the colour impression cannot be avoided and depend on several factors. For example, the iron oxide content of the glass mixture or the coating process play a role.

How does glass breakage occur?

Glass as a supercooled melt belongs to the brittle materials which, unlike metals for example, do not allow plastic deformation. If the elasticity limit is exceeded by thermal or mechanical impact, the pane will break immediately. Glass breakage is caused by external influences and is therefore generally not a material defect. Finstral glasses are hemmed at the edges after cutting in order to exclude possible material stresses at the cut edges as a cause for pane breakage.

How does thermal glass breakage occur?

If a glass pane is exposed to larger temperature differences, this can lead to thermal pane breakage. Possible causes for temperature differences within the glass pane are: partial shading by partially covering with sunshades, cast shadows from trees and roof overhangs, short distance from interior hanging blackout devices, attaching films and paints to the glass, heat sources at a short distance from the glass, dark objects directly behind the glazing, such as interior decorations, furniture or dark curtains.

→ Identifying and solving problems

Cases	Possible causes	Solution
The window cannot be closed. It appears to be unhooked at the top of the belt.	A wrong handle was made.	See page 15–16.
The window does not close properly.	Single-sash window: make sure that there is no obstacle between the frame and the sash all around.	Single-sash window: remove the cause of the obstruction, lift the sash slightly and press it closed.
	Two- or multi-sash window: the lever for blocking the second opening sash was not pressed down.	Double-sash window: make sure that the lever for opening/closing the second sash is in a vertical position. Check that the secondary sash is well closed and, if necessary, press it lightly shut by hand.
	Fittings were not cleaned and greased.	See page 85.
Water ingress on the room side: there is water on the windowsill or on the floor.	The drainage slots are dirty.	Clean the drainage slots inside and outside with a small brush or the Hoover.

Troubleshooting

→ Identifying and solving problems

Cases	Possible causes	Solution
Condensation forms on the window or on the glass pane.	The humidity is too high.	Ventilate the room as often as possible (see pages 30–31).
	There are too many plants near the window.	Place the plants away from the window.
	The room was not sufficiently ventilated.	Check the humidity often.
	The room is too cold.	Check the external causes: fresh plaster, condition of the wall, location of the room, etc. Increase the room temperature to at least 19°C.
Mould forms around the window or in the corners of the wall.	The new windows seal better than the old ones.	Ventilate the room as often as possible and eliminate the causes of dampness.
	There is high humidity and insufficient air exchange in the room.	Dry the mould area with warm air and clean it with a cloth dipped in a disinfecting detergent.
	The house is new, the construction is still damp.	If the building is still damp, ventilate several times and increase the heating temperature by a few degrees. While doing so, leave the interior doors open so that the air can circulate between the rooms.

→ Further information

Visual assessment of multi-pane insulating glass

The European standard "Glass in building" EN 1279-1:2018 differentiates between main zone and edge zone for the assessment of the visual quality of multi-pane insulating glass in the permissible characteristics.

Finstral applies the more demanding requirements of the main zone to the entire visible glass surface.

Observation conditions according to EN 1279-1:2018

- Viewing distance at least 3m from inside or outside
- Assessment of the discs in the inspection, not in the supervision
- Do not mark deviations on the disc
- Viewing angle as perpendicular to the glass surface as possible
- Viewing time maximum one minute per square metre of glass surface
- Viewing in diffuse daylight without direct sunlight and without artificial lighting

Scratches	2-fold glass	2-fold glass with 1× Multiprotect or 3-fold glass	2-fold glass with 2× Multiprotect or 3-fold glass with 1× Multiprotect	3-fold glass with 2× Multiprotect
	permissible scratch length ≤15mm	permissible scratch length ≤15mm	permissible scratch length ≤15mm	permissible scratch length ≤15mm
	permissible scratch length sum ≤45mm	permissible scratch length sum ≤57mm	permissible scratch length sum ≤68mm	permissible scratch length sum ≤79mm
Point defect diameter ≤1mm	3 points per 20cm area diameter al- lowed	3 points per 20cm area diameter al- lowed	3 points per 20cm area diameter al- lowed	4 points per 20cm area diameter al- lowed

Troubleshooting

→ Further information

Point defect diameter between >1mm and ≤2mm	2-fold glass	2-fold glass with 1× Multiprotect or 3-fold glass	2-fold glass with 2× Multiprotect or 3-fold glass with 1× Multiprotect	3-fold glass with 2× Multiprotect
Glass surface ≤1m ²	2 points permissible	3 points permissible	3 points permissible	4 points permissible
Glass surface >1m ² and ≤2m ²	3 points permissible	4 points permissible	5 points permissible	6 points permissible
Glass surface >2m ² and ≤3m ²	5 points permissible	7 points permissible	8 points permissible	9 points permissible
Glass surface >3m ² and ≤4m ²	7 points permissible	10 points permissible	11 points permissible	13 points permissible
Glass surface >4m ² and ≤5m ²	9 points permissible	13 points permissible	14 points permissible	17 points allowed
Glass surface >5m ² and ≤6m ²	11 points permissible	16 points allowed	17 points allowed	21 points allowed
Glass surface >6m ² and ≤7m ²	13 points permissible	19 points allowed	20 points allowed	25 points allowed
point-shaped residues ≤1mm	3 points per 20cm area diameter allowed	4 points per 20cm area diameter allowed	5 points per 20cm area diameter allowed	6 points per 20cm area diameter allowed
point-shaped residues between >1mm and ≤3mm	2 points per 20cm area diameter allowed	3 points per 20cm area diameter allowed	3 points per 20cm area diameter allowed	4 points per 20cm area diameter allowed

Other features

For other characteristics for assessing the visual quality of multi-pane insulating glass, the requirements according to EN 1279-1:2018 apply.

Technical service

With Finstral, you always get everything from a single source. We work according to the most demanding quality guidelines and also carefully check every window and every door during the production process at our in-house quality control. This always guarantees the highest quality and the certainty of receiving a perfect product.

Service from the experts

Should you still require our technical service, please contact your nearest Finstral Studio (see reverse). Describe your request as precisely as possible and give us the identification number on the element. Technical service is carried out by our specialised Finstral staff. All spare parts and materials used are original Finstral products.

The identification number

A label with the identification number is attached to each window and door element.

The label

The label is always affixed to the hinge side at the top of the side of the first opening sash on windows, casement windows and balcony doors. On sliding doors, the identification number is located on the top of the handle. Please do not remove this label even after installation. It helps us to quickly find and view technical data of the faulty element.

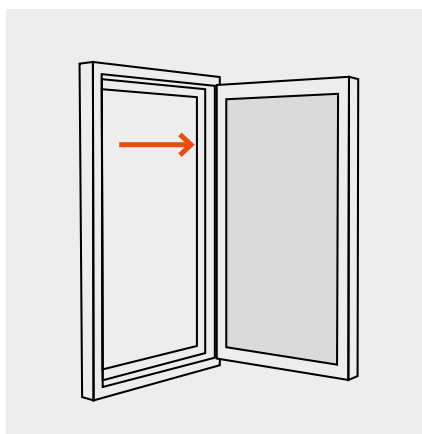

Identification number for window/door

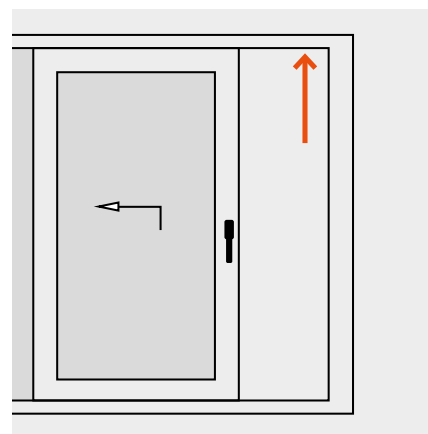

Identification number for sliding door

Packaging materials

A large proportion of the packaging materials used to package Finstral's products and assembly parts are recyclable. Please collect and dispose of them separately.

Copyright

© Finstral AG, Unterinn/Ritten, 2024
All rights reserved

The Finstral logo is a registered image mark of Finstral AG.
The name "Finstral" is a registered word mark of Finstral AG.

Edition dated September 2024
Item number 60-0301-00-07

Subject to technical changes. Colour may differ from original products owing to printing processes. The presentation and description of the products in the prospectuses are for indicative purposes only. Should the product delivered deviate in any way from the product appearing in the advertising material, this shall not constitute any defect or deviation as only the order may be used as a benchmark.



Always there for you. Call us or call in.

Finstral Studio Unterinn

Headquarters, 600 m² exhibition
Unterinn/Ritten, Italy
T +39 0471 296611
finstral.com/unterinn

Finstral Studio Friedberg

Showroom, 1,000 m² exhibition
Derching/Friedberg, Germany
T +49 821 2071780
finstral.com/friedberg

Finstral Studio Apeldoorn

Showroom, 350 m² exhibition
BN Apeldoorn, Netherlands
T +31 055 5380060
finstral.com/apeldoorn

Finstral Studio Wihr-au-Val

Showroom, 350 m² exhibition
Wihr-au-Val, France
T +33 03 89717100
finstral.com/wihrauval

Finstral Studio Tarragona

Showroom, 320 m² exhibition
43144 Vallmoll - Tarragona, Spain
T +34 977 637001
finstral.com/tarragona

Finstral Studio Crissier

Showroom, 180 m² exhibition
Crissier, Switzerland
T +41 021 8861240
finstral.com/crissier

Finstral Studio Brussels

Showroom, 600 m² exhibition
Zaventem, Belgium
T +32 02 616 09 17
finstral.com/brussels

Finstral Studios in your vicinity:

finstral.com/dealer-search